

3312015COM 1 Drawer Cabinet

Ameriwood
HOME

Date of Purchase ___ / ___ / ___
Lot Number:

B343312015COM0

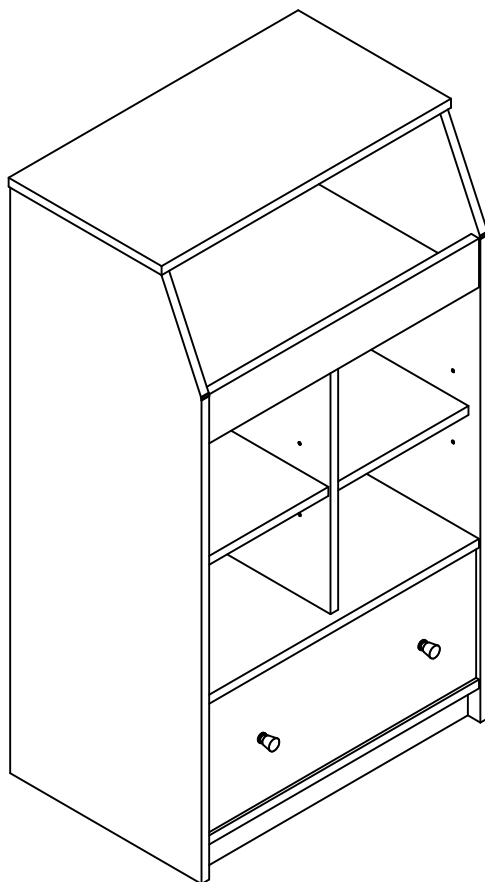

Do Not Return This Product!
Contact our customer service team for help first.
Call: 1-800-489-3351 (toll free)
Monday-Friday 9am - 5pm CST
Visit: www.ameriwoodhome.com

THIS INSTRUCTION BOOKLET CONTAINS **IMPORTANT** SAFETY INFORMATION. PLEASE READ AND KEEP FOR FUTURE REFERENCE.

Secure Your Furniture

Keep your home and family safe with the wall anchor kit that is included with the product.

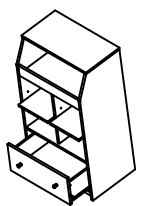

Serious or fatal crushing injuries can occur from tipping furniture.

WARNING: Manufacturer assumes no liability for improper installation or excessive loads placed on screws or bracket. This wall anchor is not a substitute for proper adult supervision.



Follow Ameriwood Home



Contact Us!

Do NOT return this product!

Contact our friendly customer service team first for help.



Visit ameriwoodhome.com to view the limited warranty valid in the U.S. and Canada.

Assembly Tips



Helpful Hints

PEOPLE NEEDED FOR ASSEMBLY: 1-2

- Open your item in the area you plan to keep it to avoid excessive heavy lifting.
- Identify, sort and count the parts before attempting assembly.
- Compression dowels are lightly tapped in with a hammer.
- Slides are labeled with a **R** (right) and **L** (left) for proper placement.
- Make sure to always face the point on the top of the Cam Lock towards the outer edge.
- Use all the nails provided for the back panel and spread them out equally.
- Back panel must be used to make sure your unit is sturdy.
- Do NOT use harsh chemicals or abrasive cleaners on this item.
- Never push, pull, or drag your furniture.



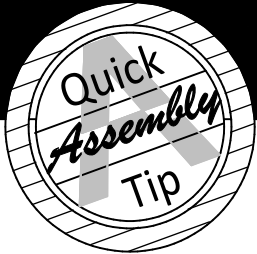

Before You Start

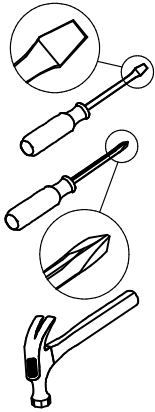

- ✓ Read through each step carefully and follow the proper order
- ✓ Separate and count all your parts and hardware
Parts are labeled on the surface or edge of the part
- ✓ Give yourself enough room for the assembly process
- ✓ Have the following tools: Flat Head Screwdriver, #2 Phillips Head Screwdriver and Hammer
- ✓ Caution: If using a power drill or power screwdriver for screwing, please be aware to slow down and stop when screw is tight. Failure to do so may result in stripping the screw.

Cam Lock Fastening System

This Cam Lock Fastening System will be used throughout the assembly process.

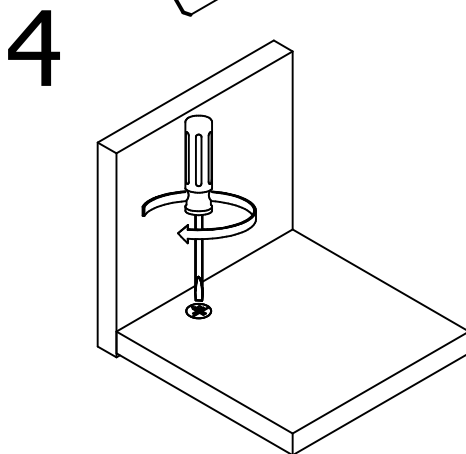
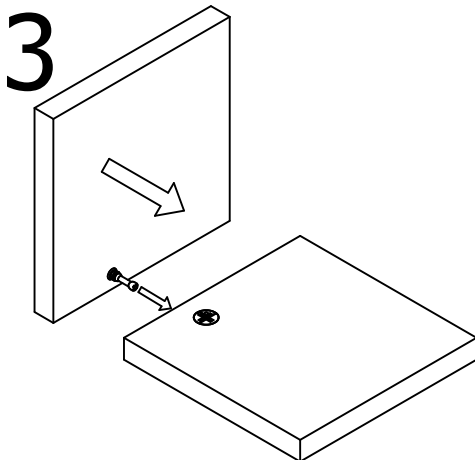
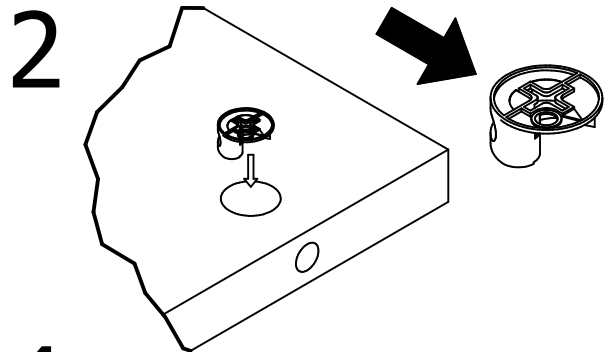
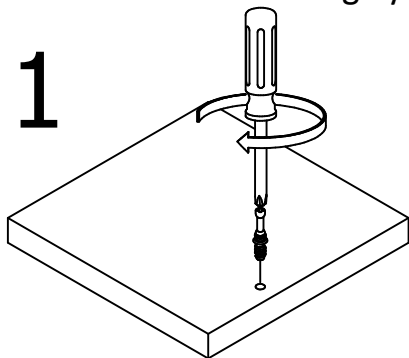

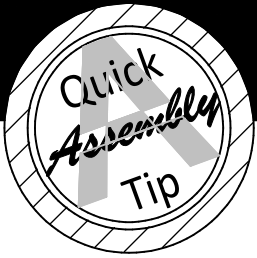

Before You Start

Please Note:

You may need to lightly tap the wood dowels into the holes during your assembly process.

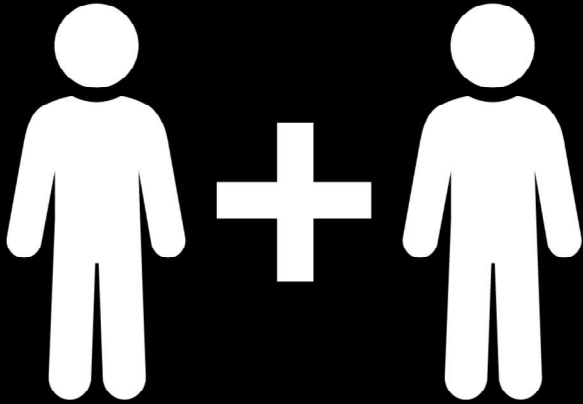
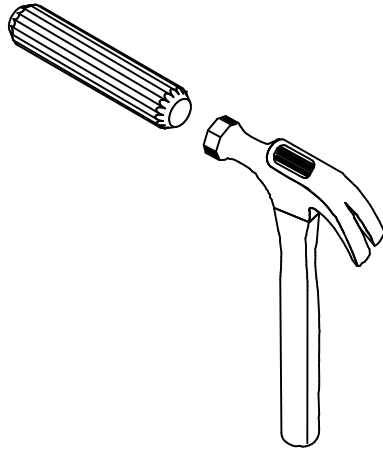

2 PEOPLE NEEDED FOR ASSEMBLY

**2 PERSONAS NECESITADAS
PARA LA ASAMBLEA**

**2 PERSONNES NÉCESSAIRES
POUR L'ASSEMBLAGE**

CAUTION: Failure to use 2 people for assembly could result in unit damage or personal injury.

PRECAUCIÓN: Si no se utilizan 2 personas para el ensamblaje, se pueden producir daños en la unidad o lesiones personales.

ATTENTION: Échec d'utiliser 2 personnes pour l'assemblage peut causer du dommage au meuble ou causer des blessures.

Board Identification

Not actual size

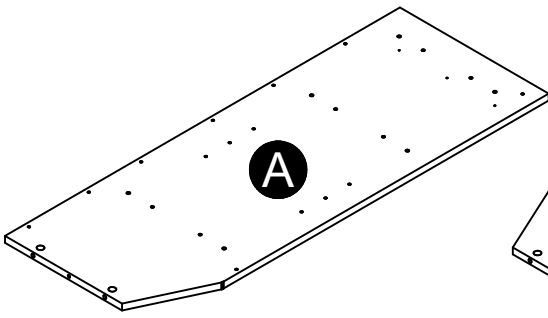

Left Panel
33312015010

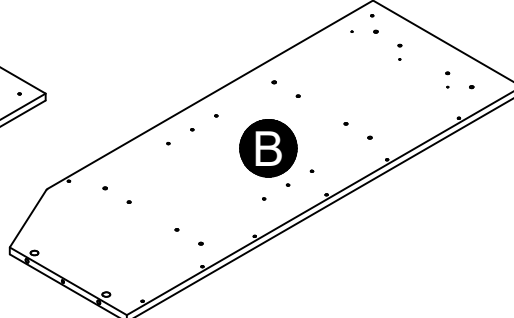

Right Panel
33312015020

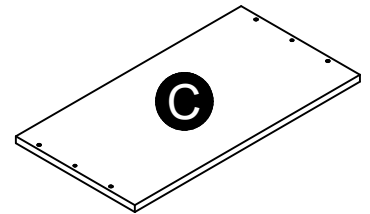

Top
36252015030

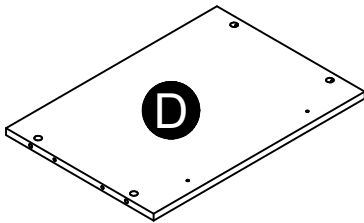

Bottom
36252015040

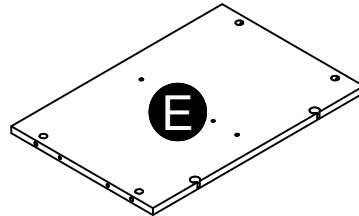

Shelf
33312015050

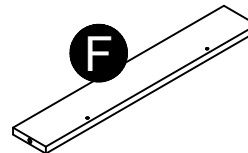

Front Rail
36252015060

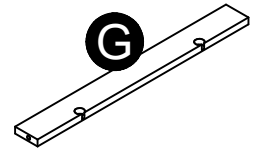

Kick
36252015070

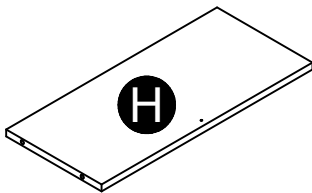

Upper Back
36252015080

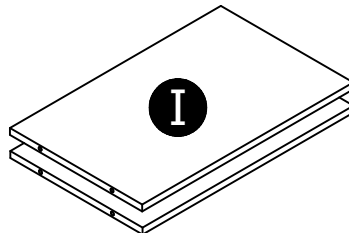

Lower Back (x2)
33312015090

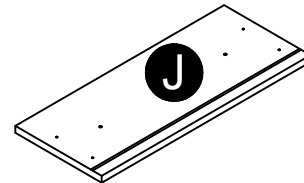

Drawer Front
36252015100

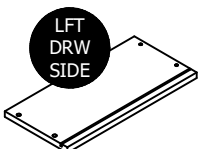

Left Drawer Side
39991167346410L

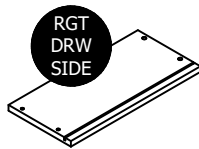

Right Drawer Side
39991167346410R

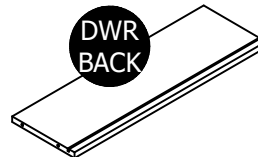

Drawer Back
39991167051217B

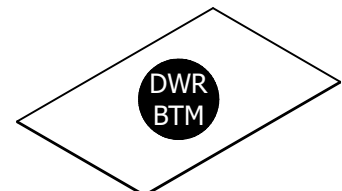

Drawer Bottom
39991340052310D

Board Identification

Not actual size

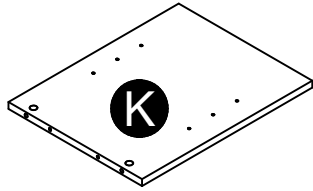

Partition
33312015110

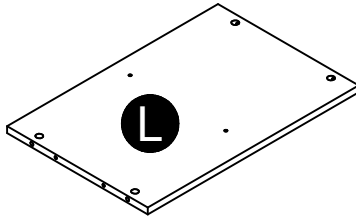

Lower Shelf
33312015120

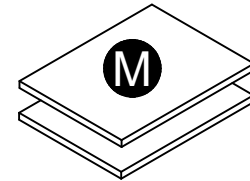

Adjustable Shelf (x2)
33312015130

Board Identification

Not actual size

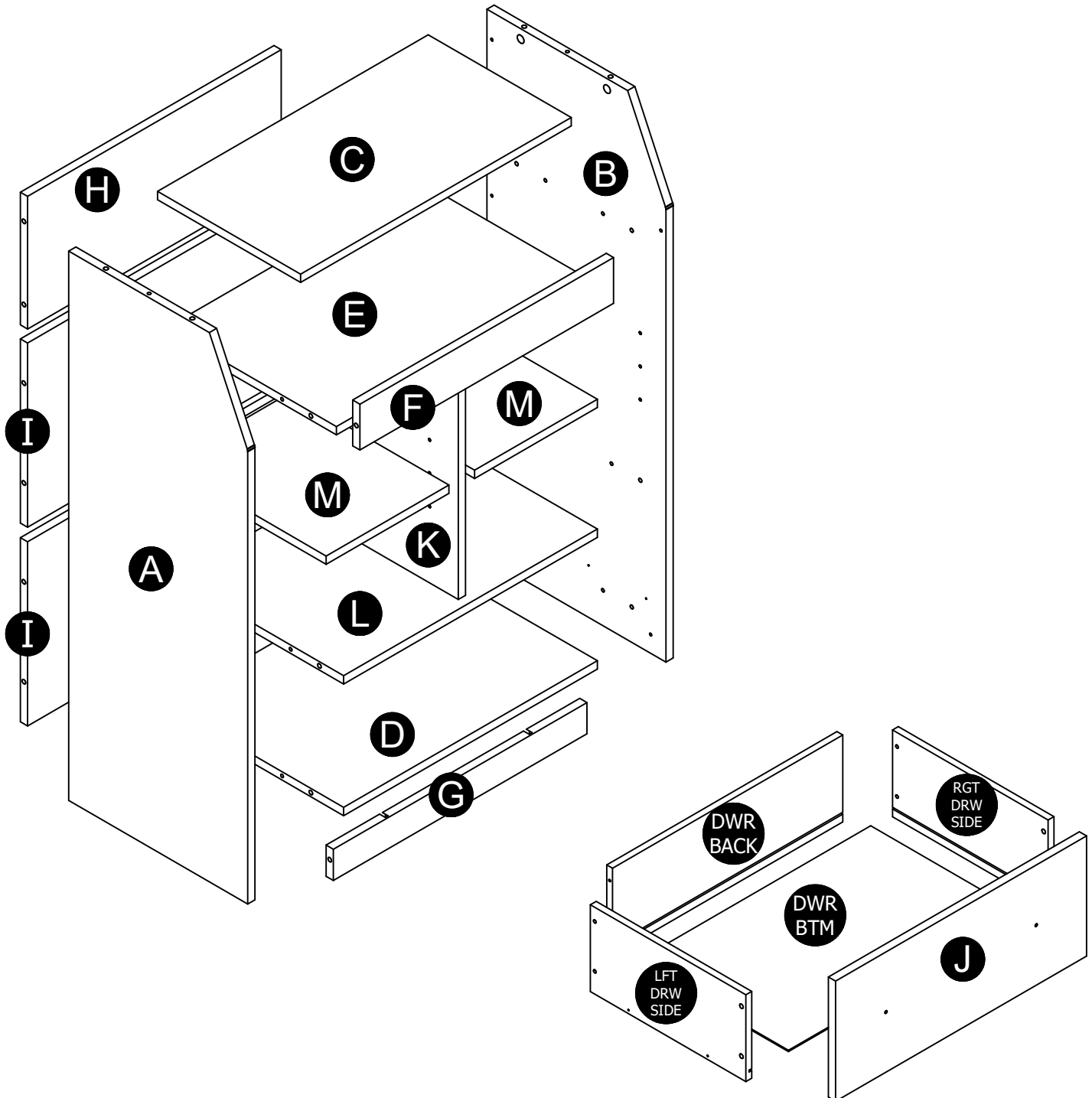

Part List

Actual Size

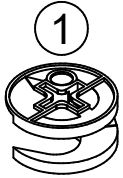

(x18)
#A22620
cam lock

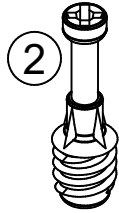

(x18)
#A22610
cam bolt



(x16)
#A21670
wood dowel

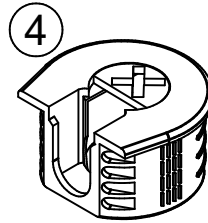

(x4)
#A22820
connector



(x4)
#A22810
connector bolt

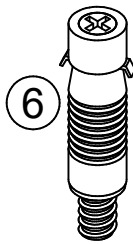

(x16)
#A21960
hidden fastener



(x8)
#A12120
7/16" screw



(x10)
#A11080
7/16" screw

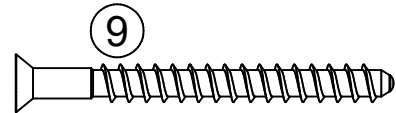

(x2)
#A23030
confirmat screw

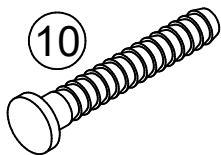

(x4)
#A21975
drive fastener

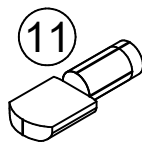

(x8)
#A80250
shelf support



(x2)
#A17400
7/8" bolt

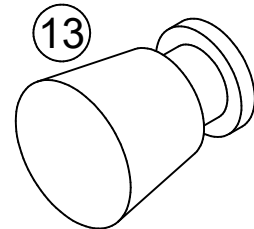

(x2)
#A50265
knob

Part List

Not actual size

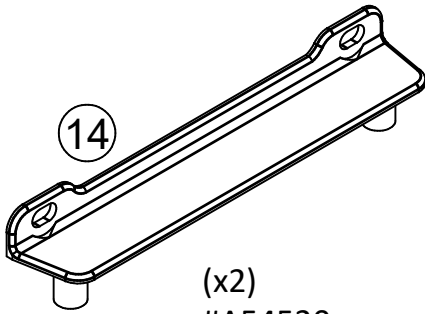

(x2)
#A54520
drawer bracket

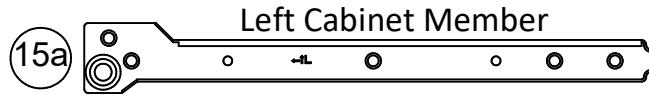

Left Cabinet Member



Right Cabinet Member

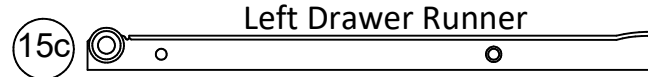

Left Drawer Runner



Right Drawer Runner

(x1)
#A56740
slide

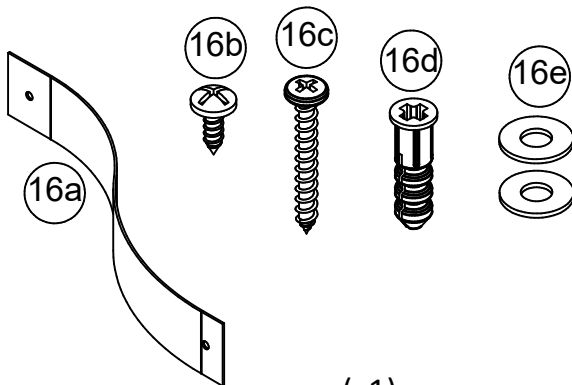

(x1)
#A84000
safety strap kit

STEP 1

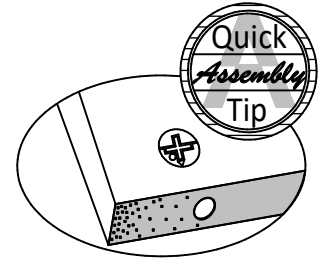
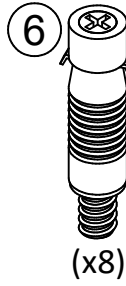
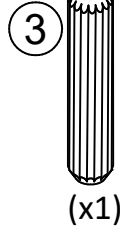
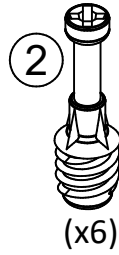
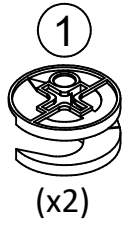
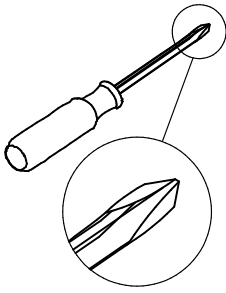

Proper orientation of CAM LOCK

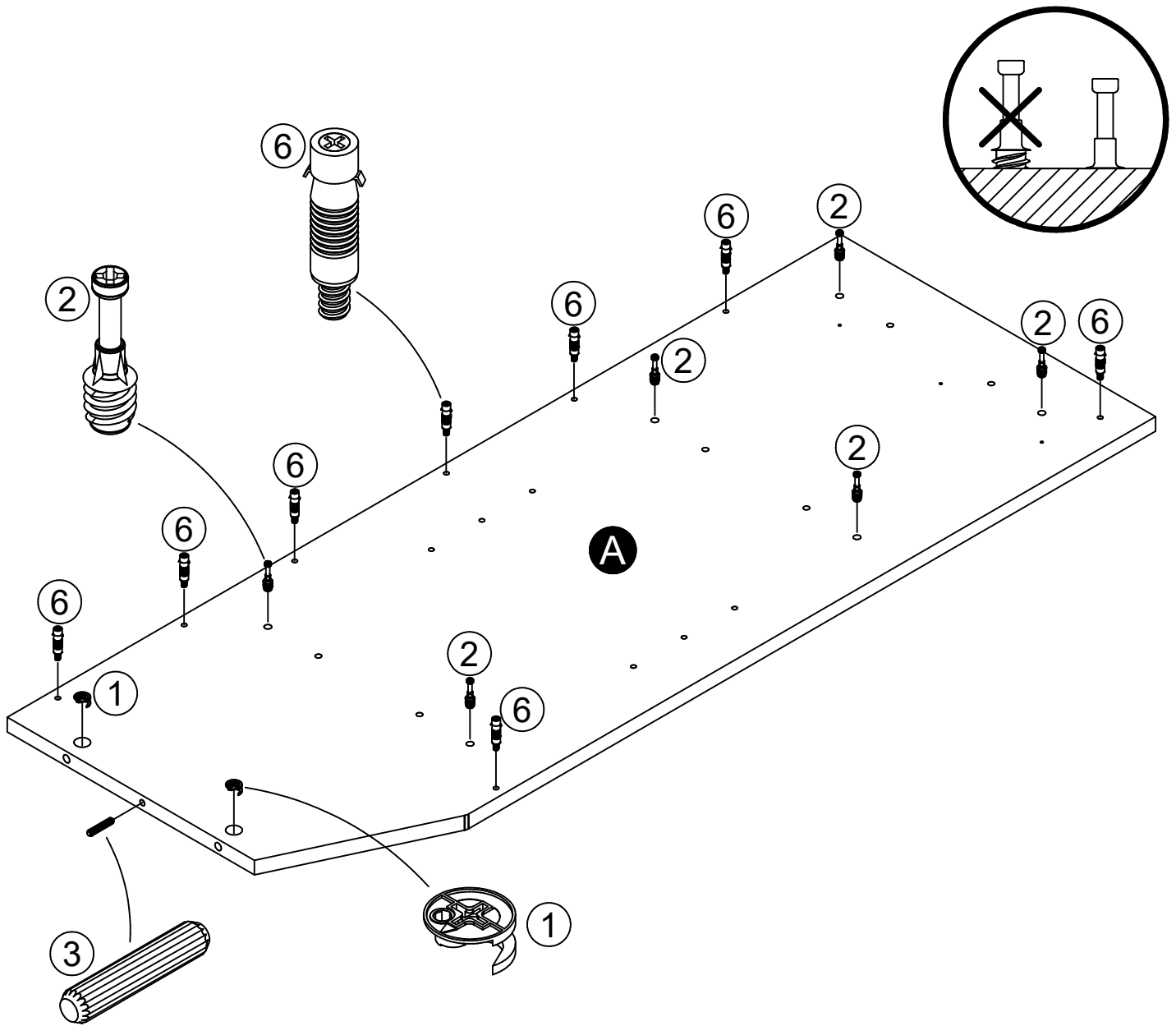

STEP 2

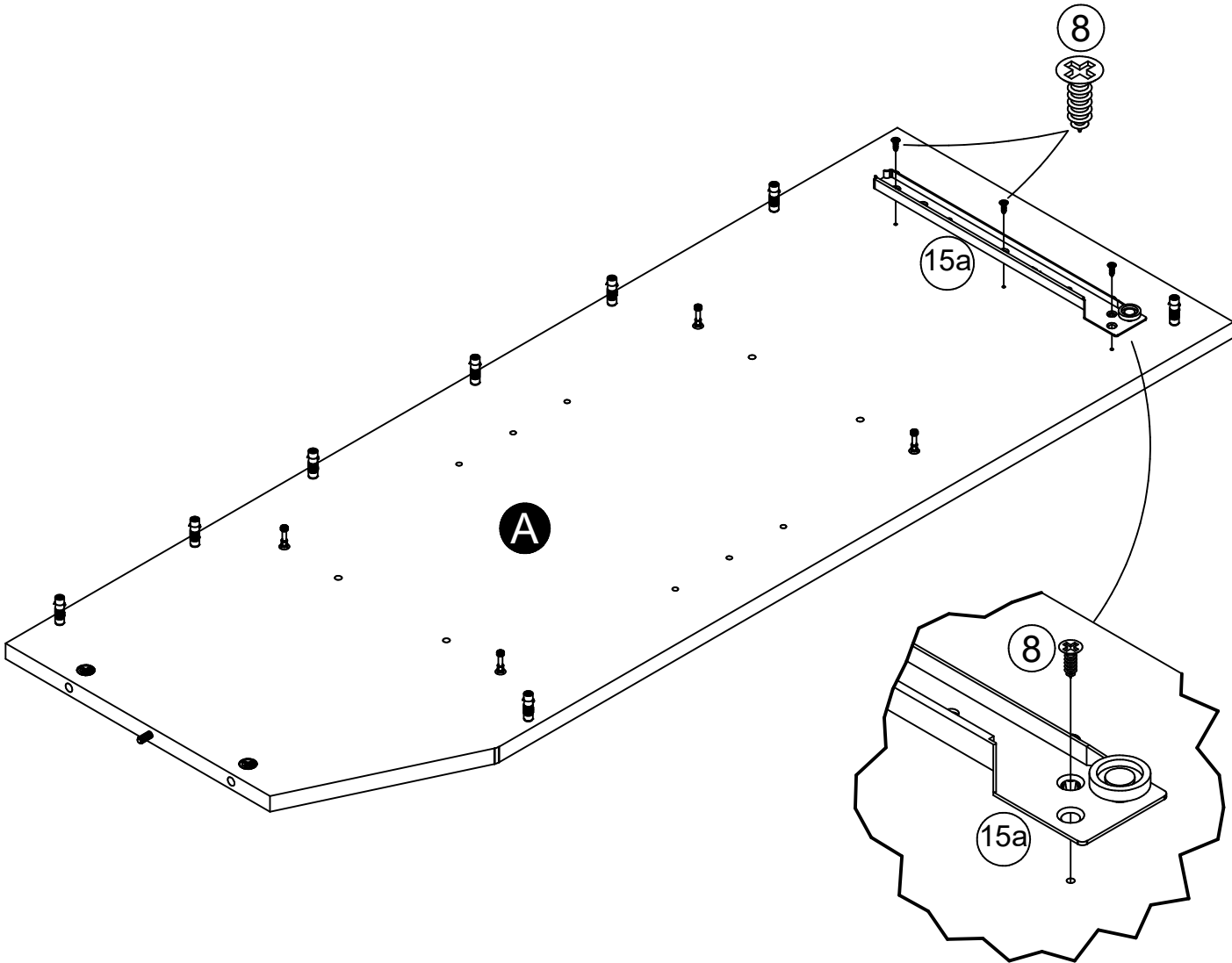
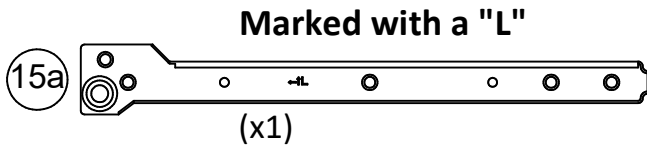
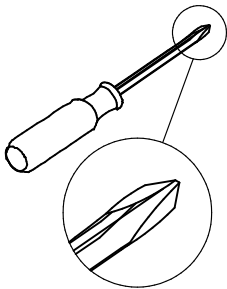

STEP 3

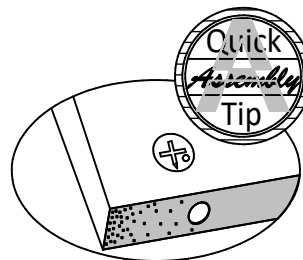
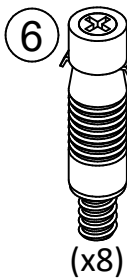
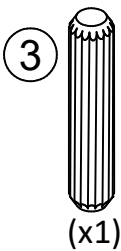
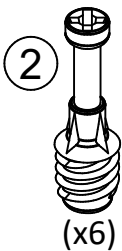
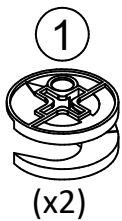
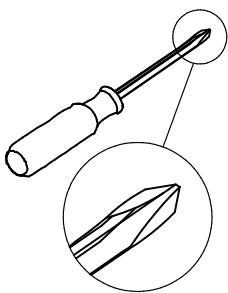

Proper orientation of CAM LOCK

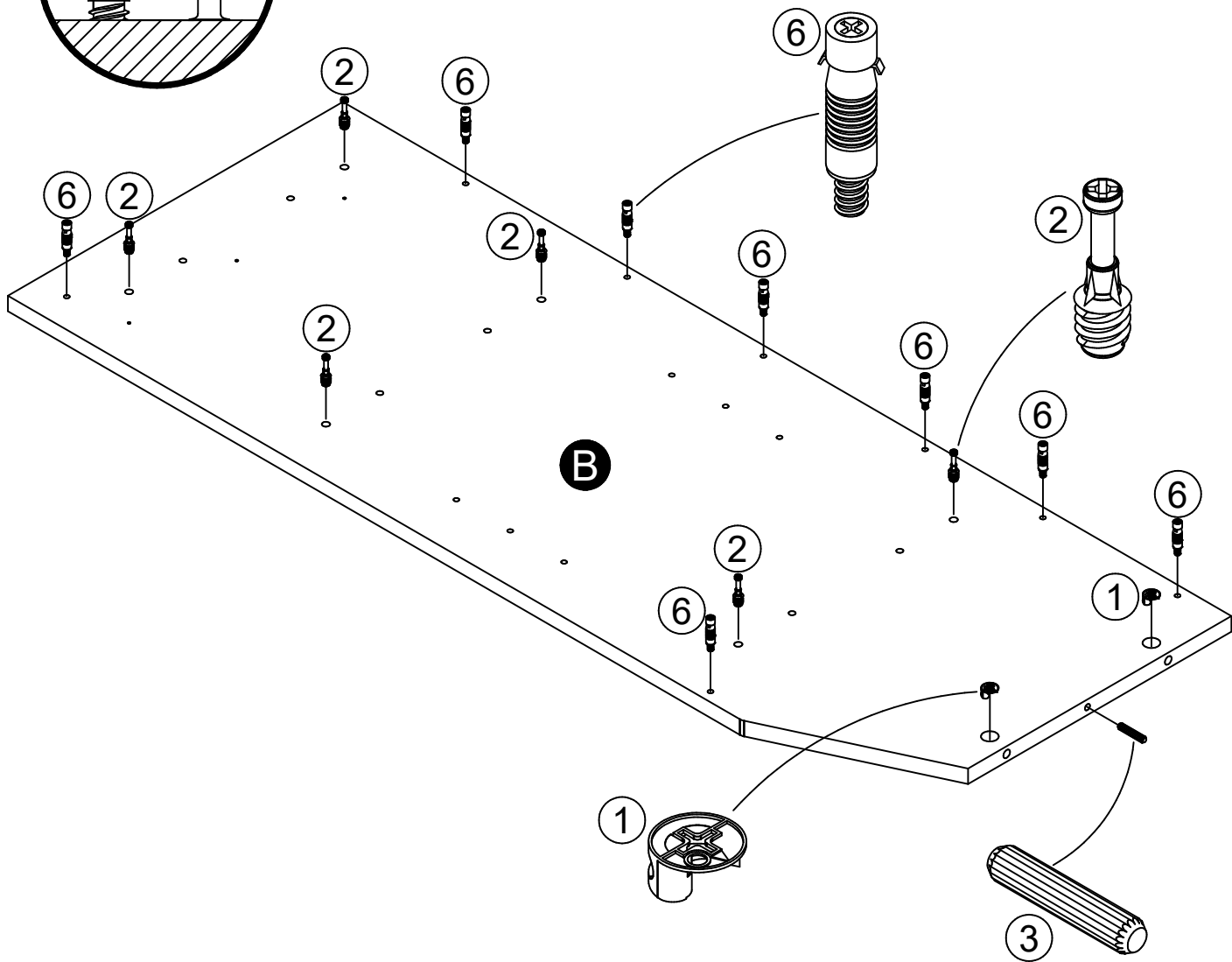
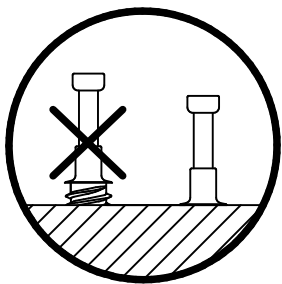

STEP 4

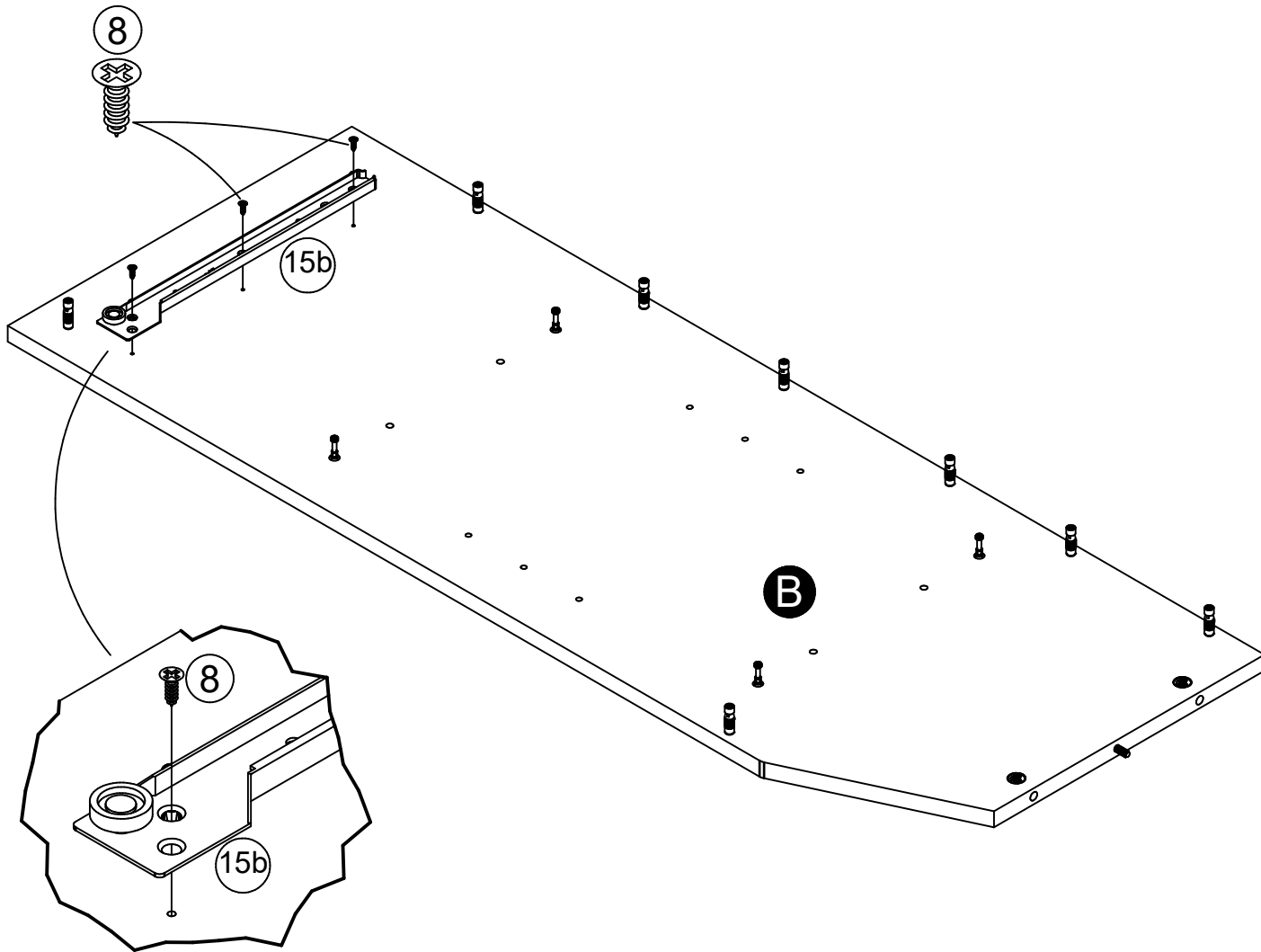
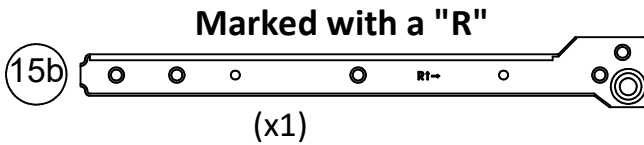
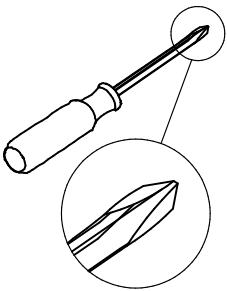

STEP 5

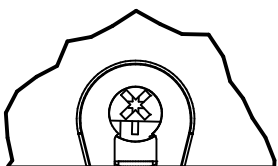
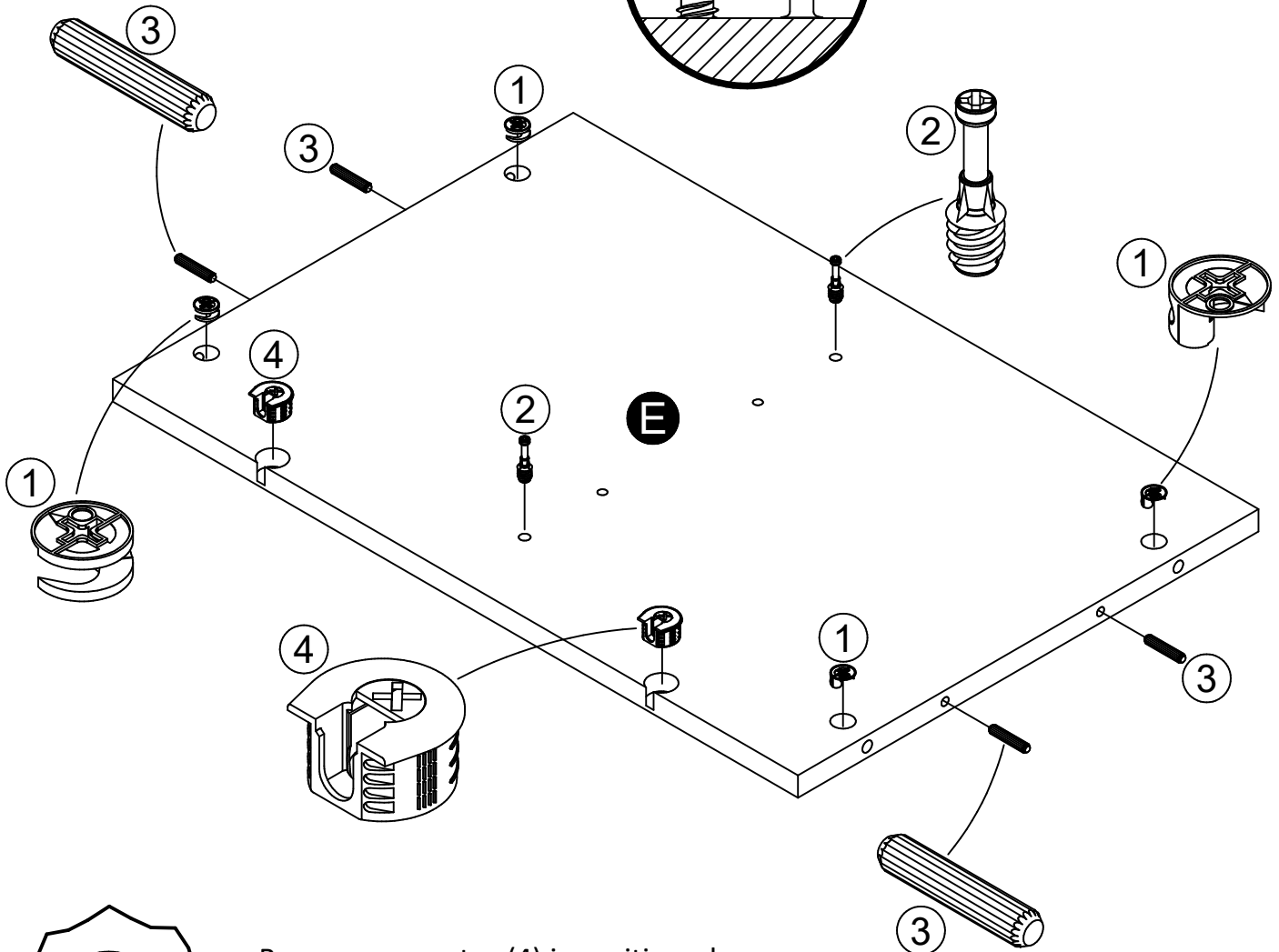
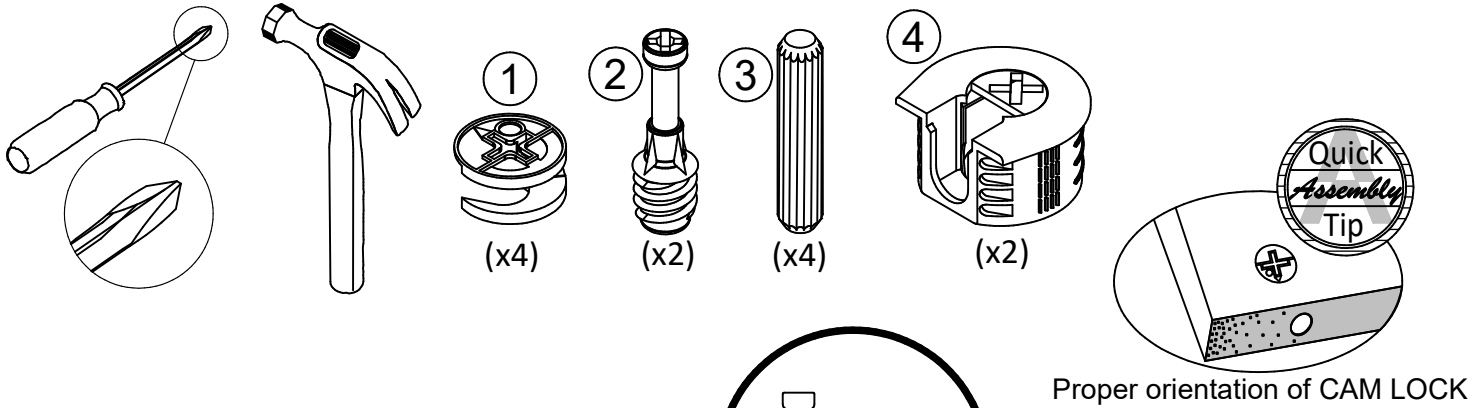

Be sure connector (4) is positioned as shown before inserting into hole. Tap with a hammer to fully insert.

STEP 6

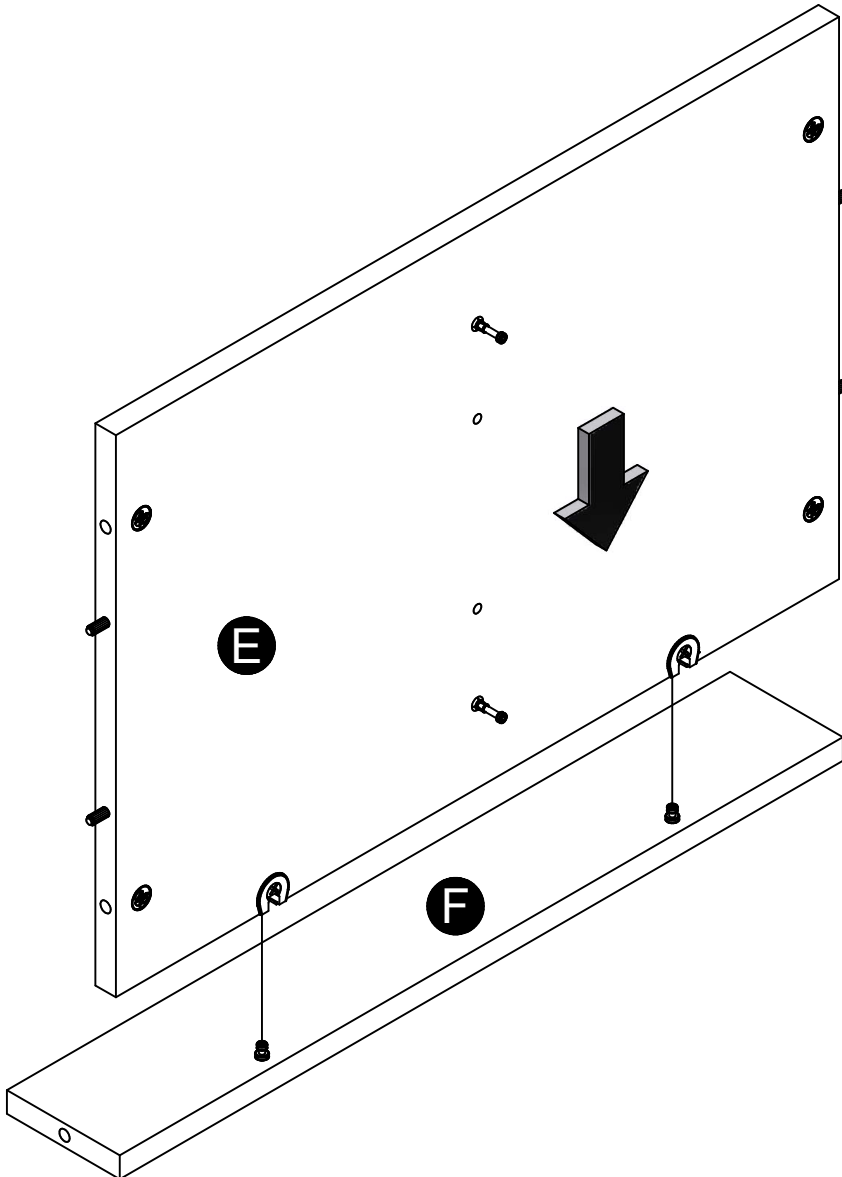
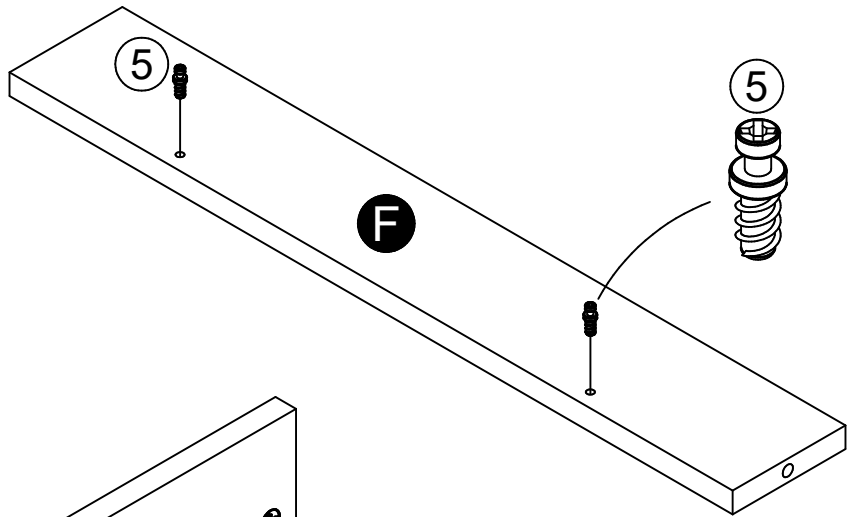
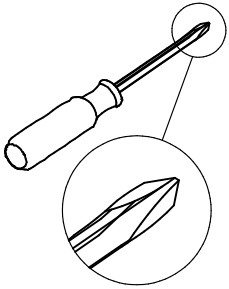

Turn screw clockwise to lock.

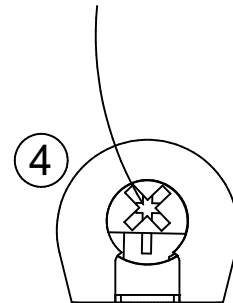

STEP 7

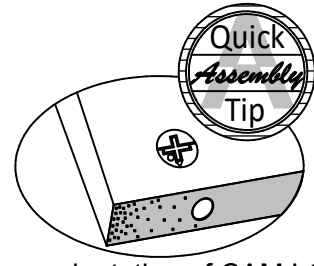
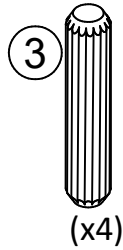
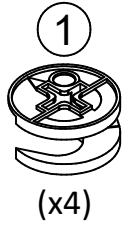
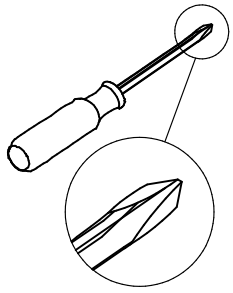

Proper orientation of CAM LOCK

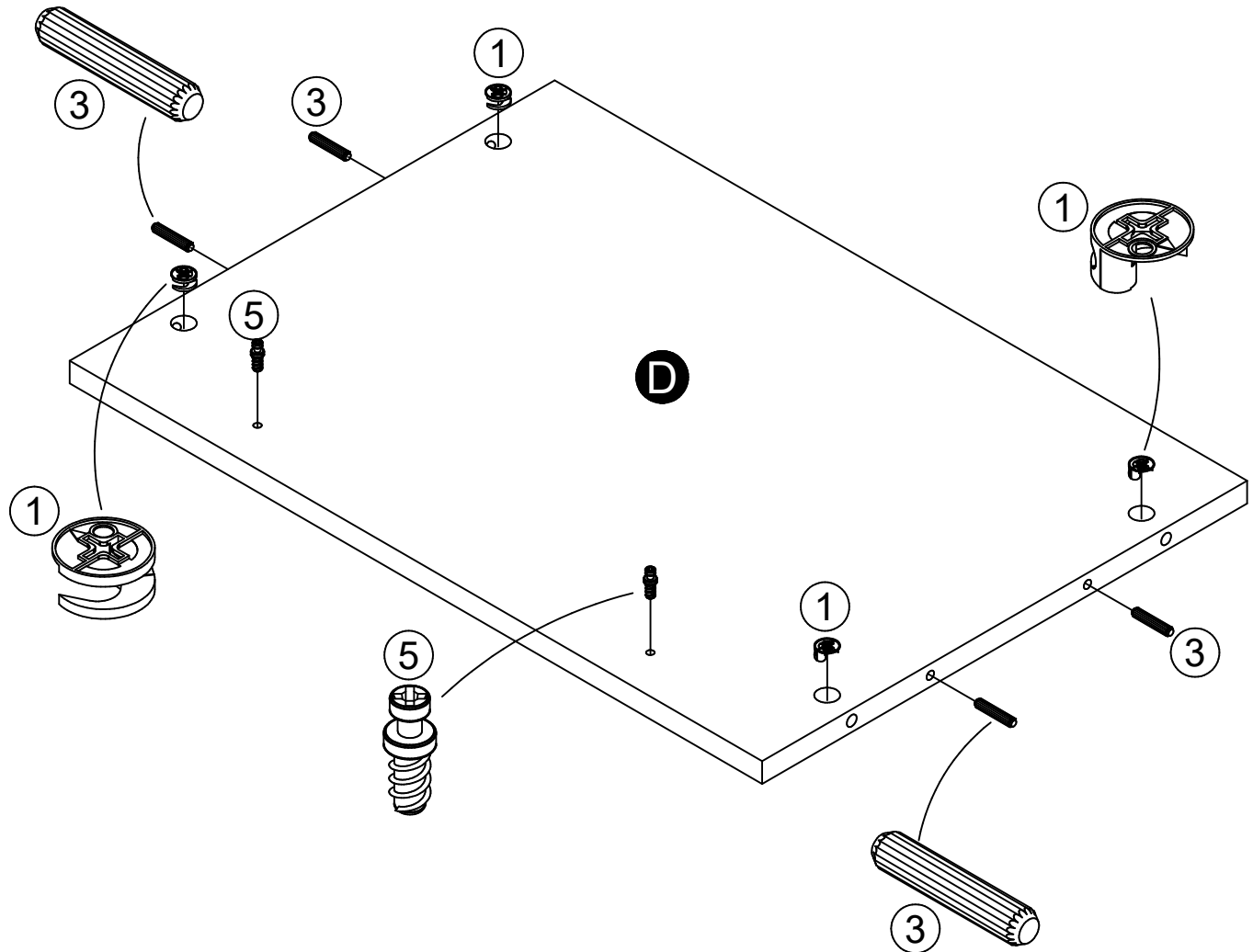

STEP 8

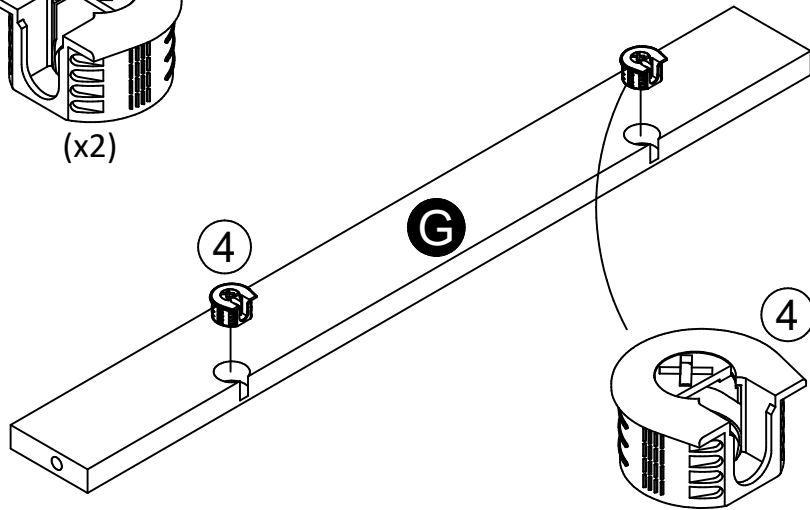
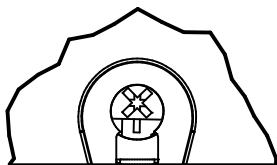
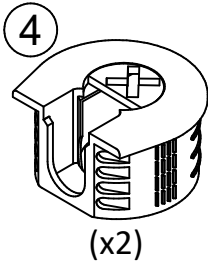
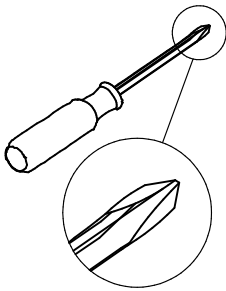

Be sure connector (4) is positioned as shown before inserting into hole. Tap with a hammer to fully insert.

Turn screw clockwise to lock.

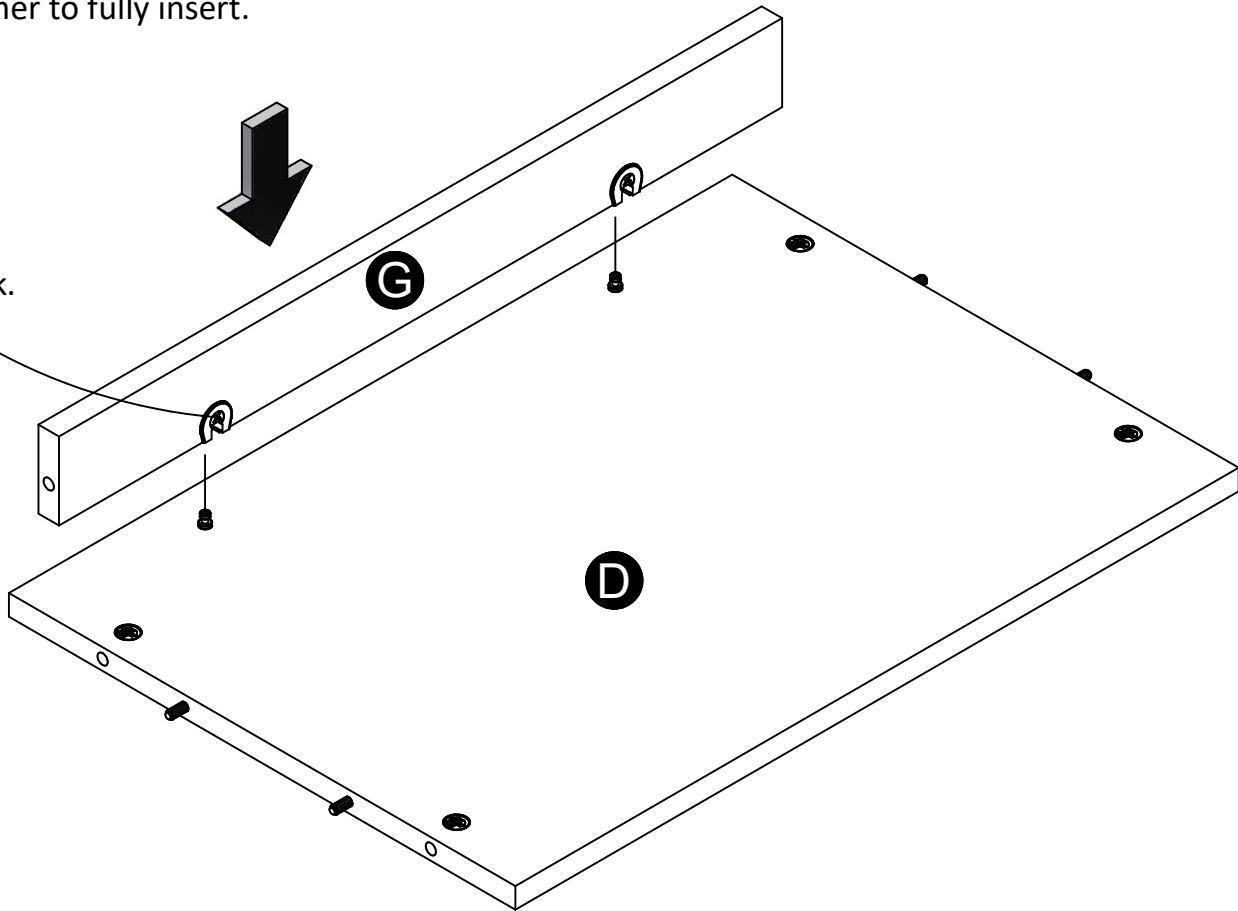

STEP 9

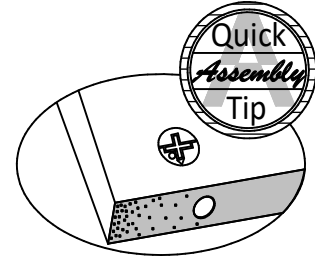
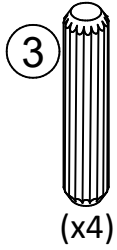
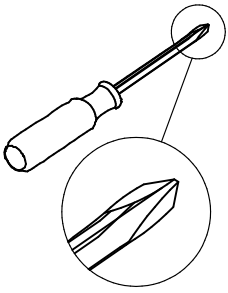

Proper orientation of CAM LOCK

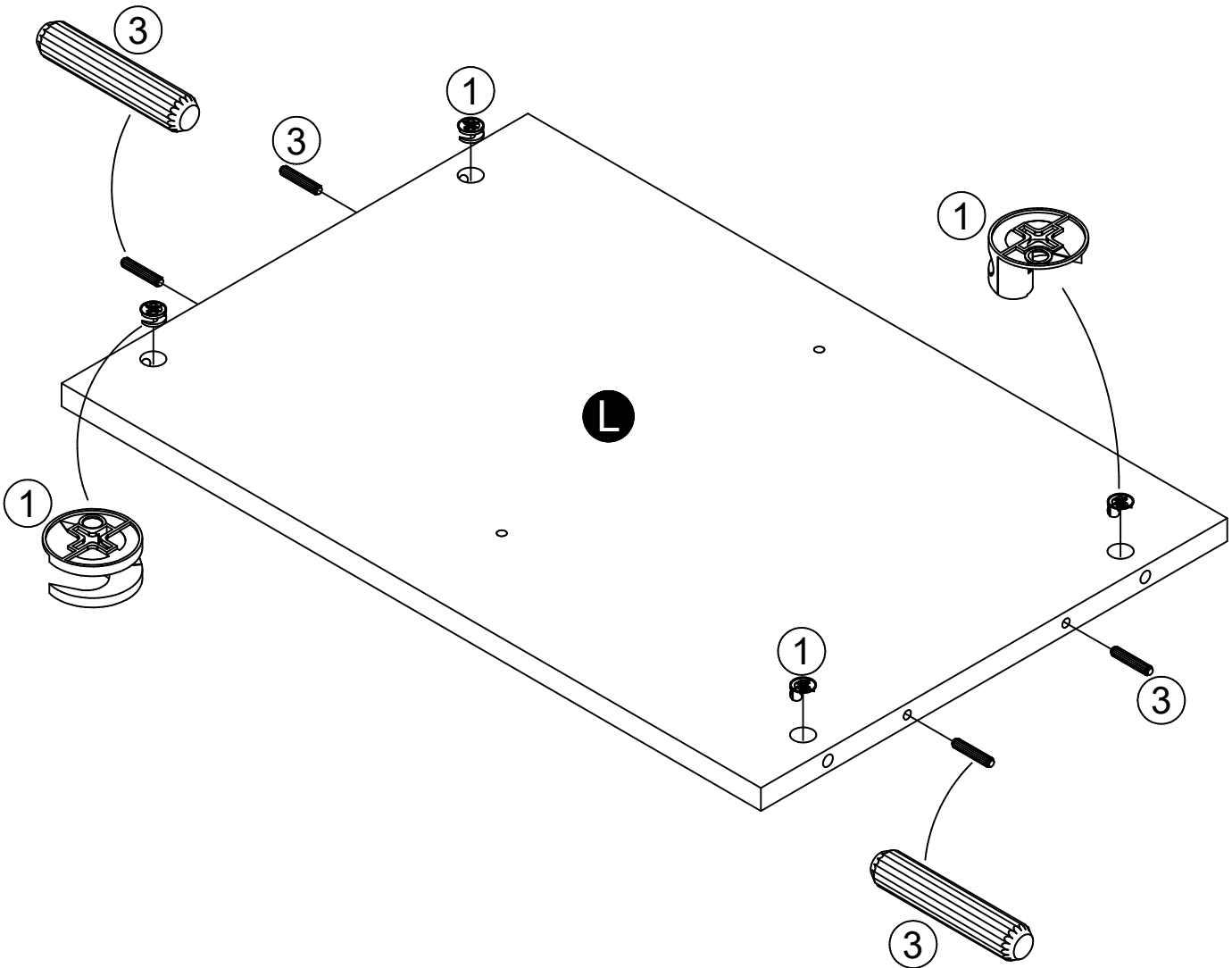

STEP 10

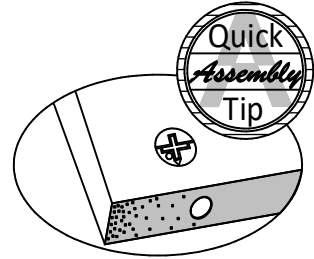
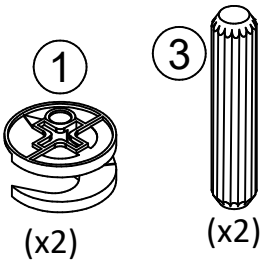

Proper orientation of CAM LOCK

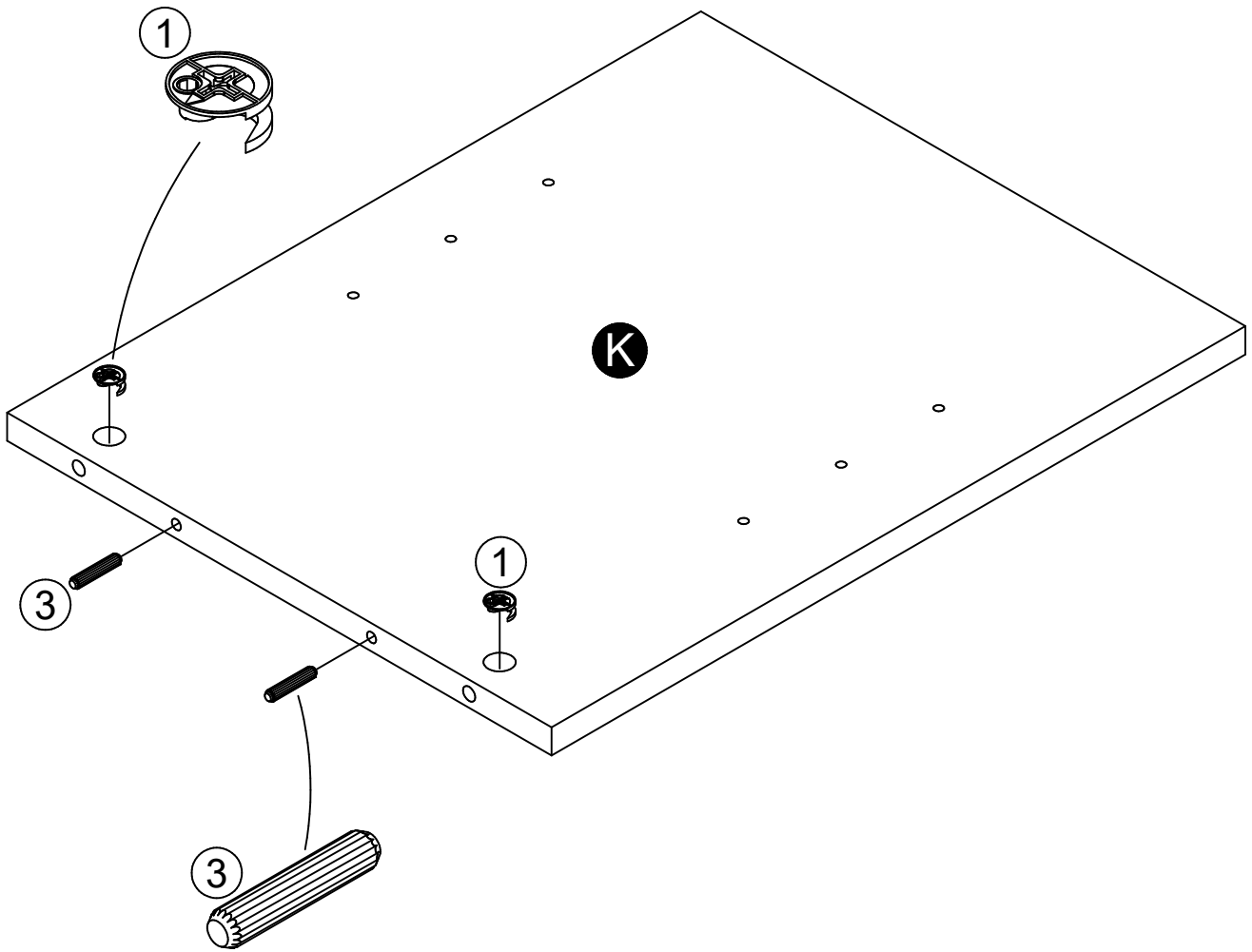

STEP 11

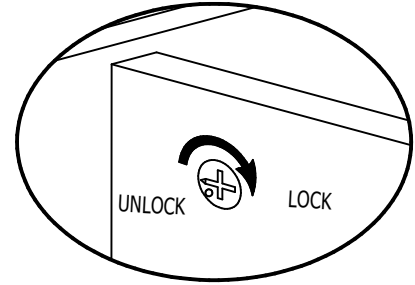
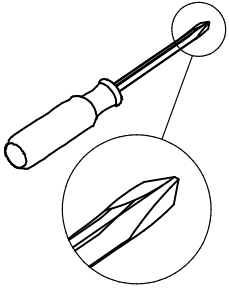

finished edge

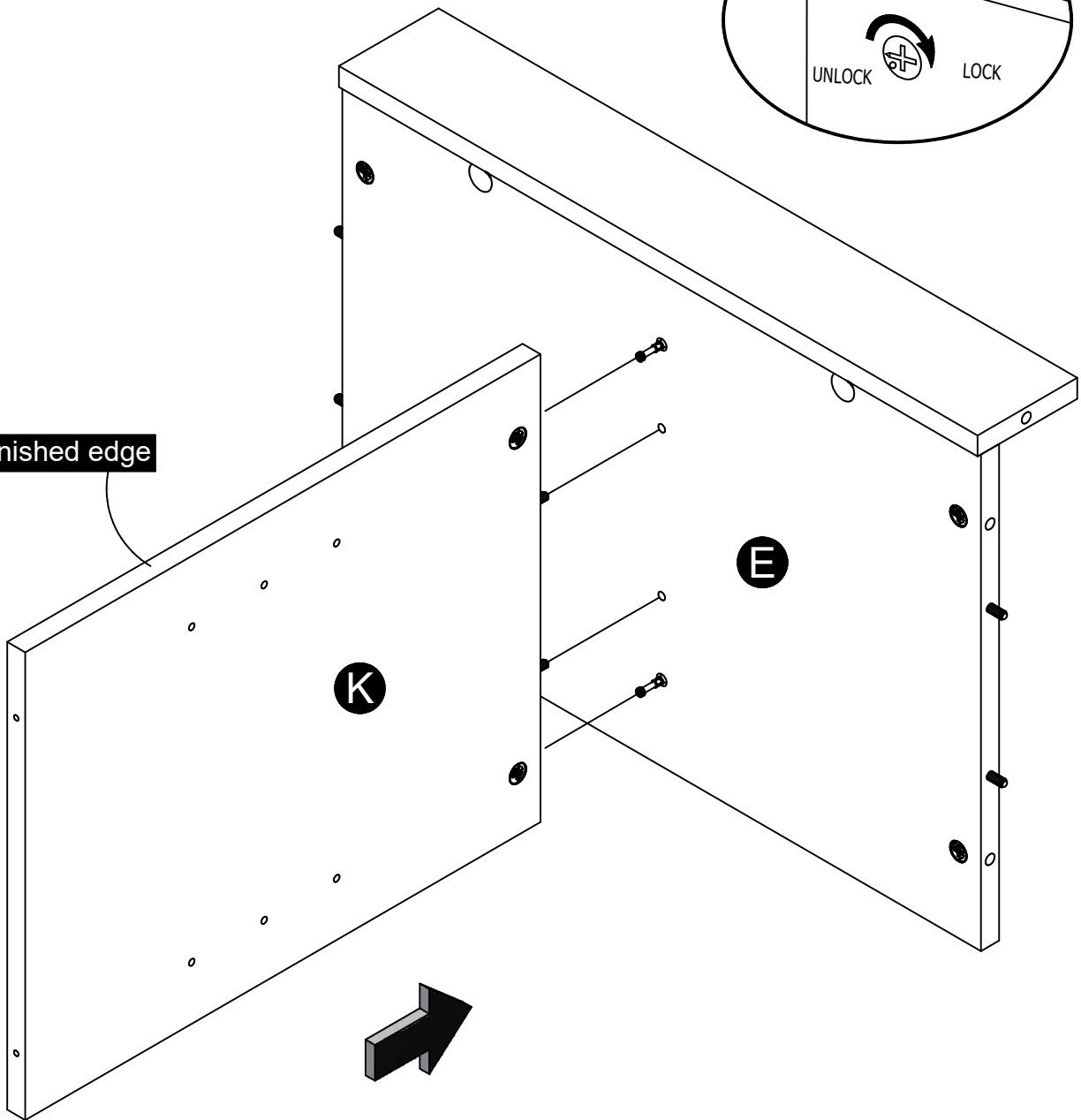

STEP 12

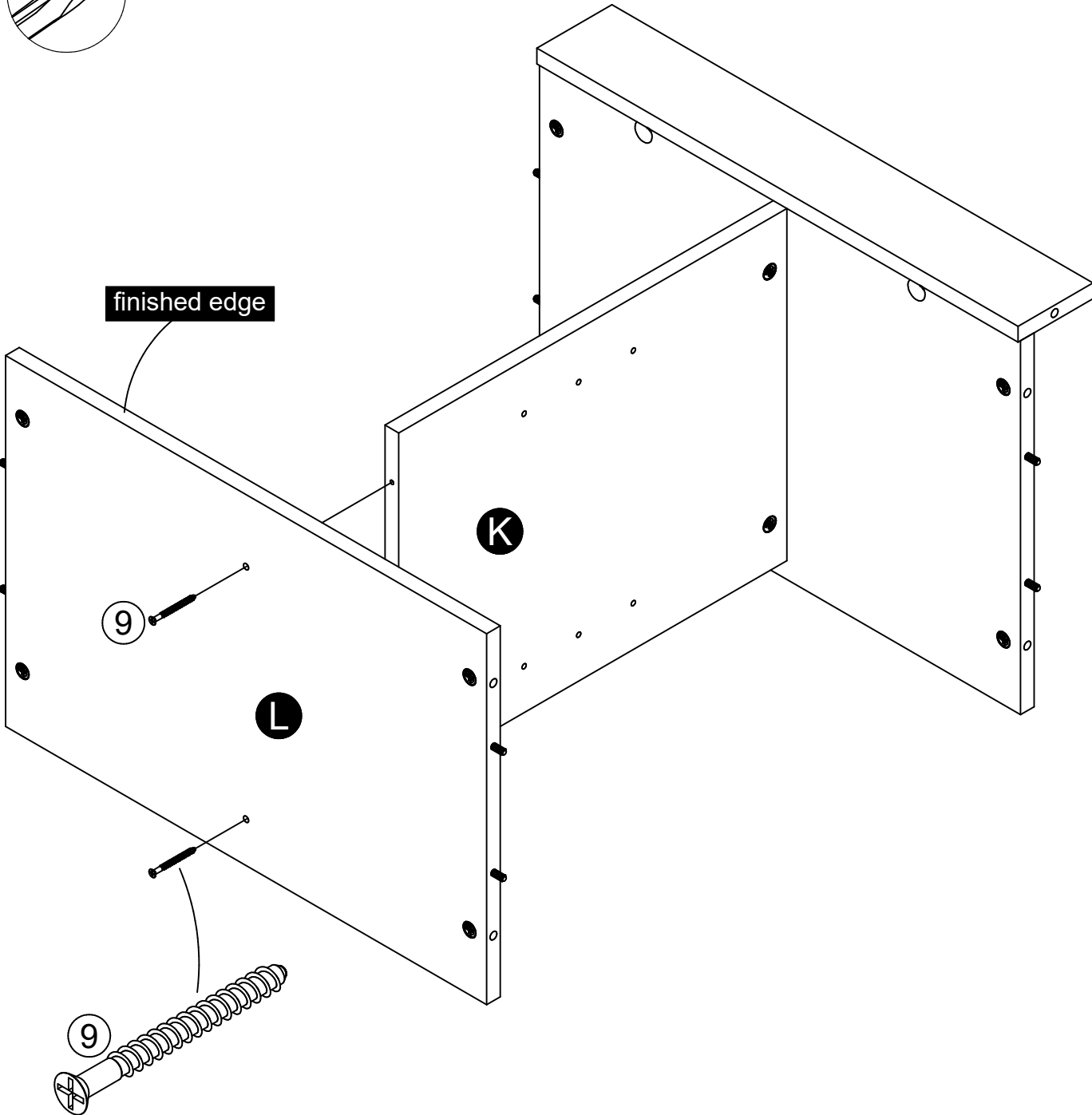
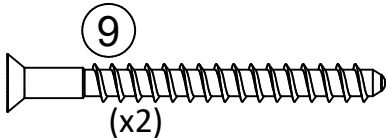
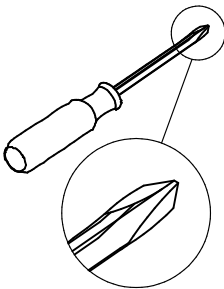

STEP 13

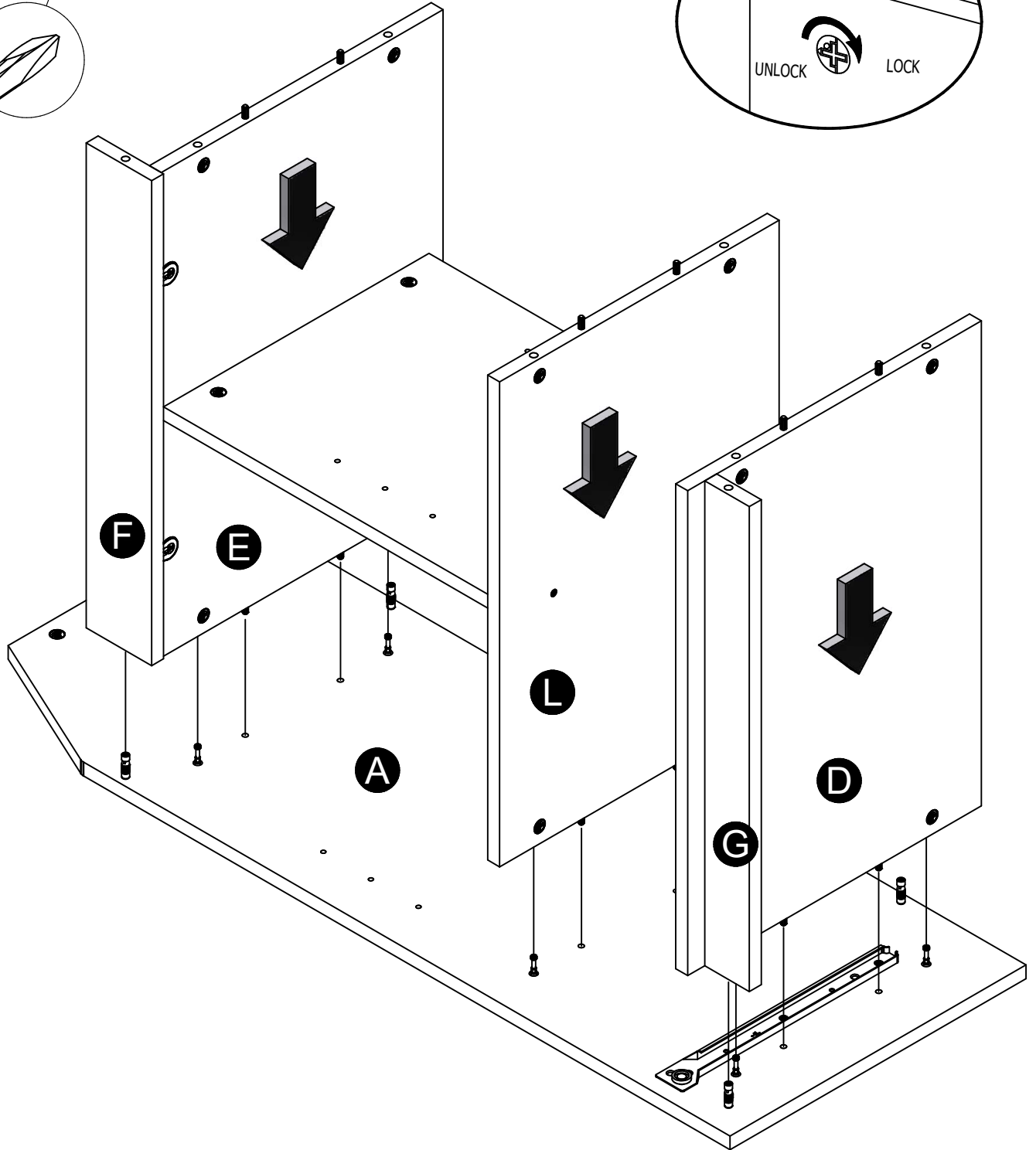
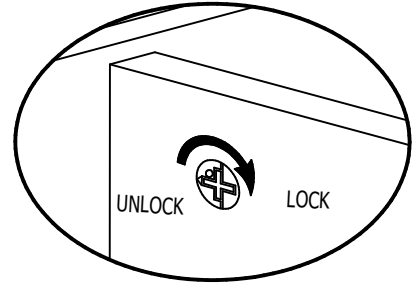
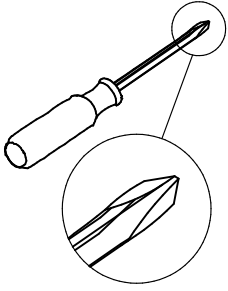

STEP 14

Note:
Hole to the top and on back side.

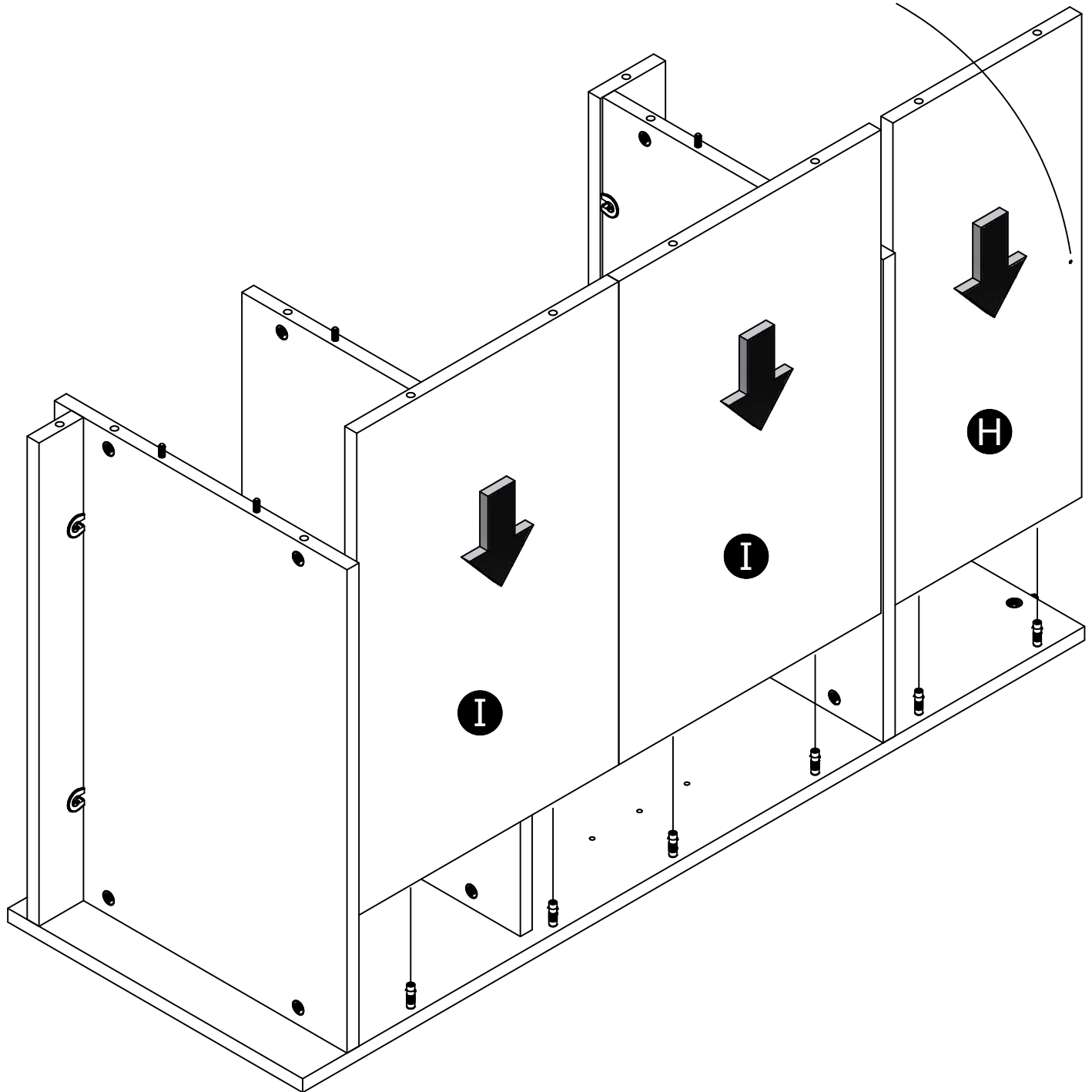

STEP 15

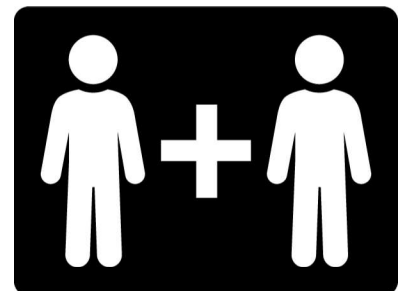
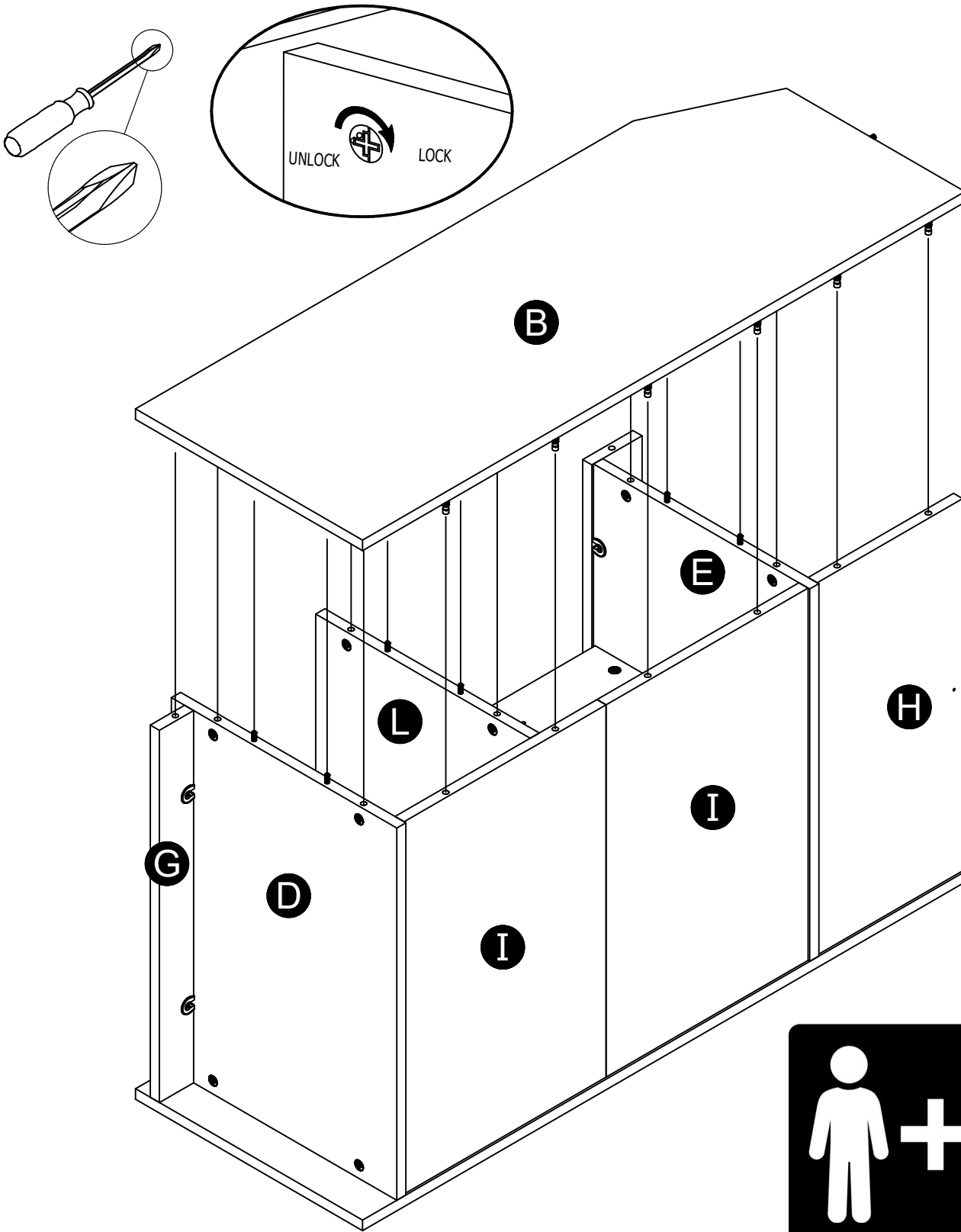

STEP 16

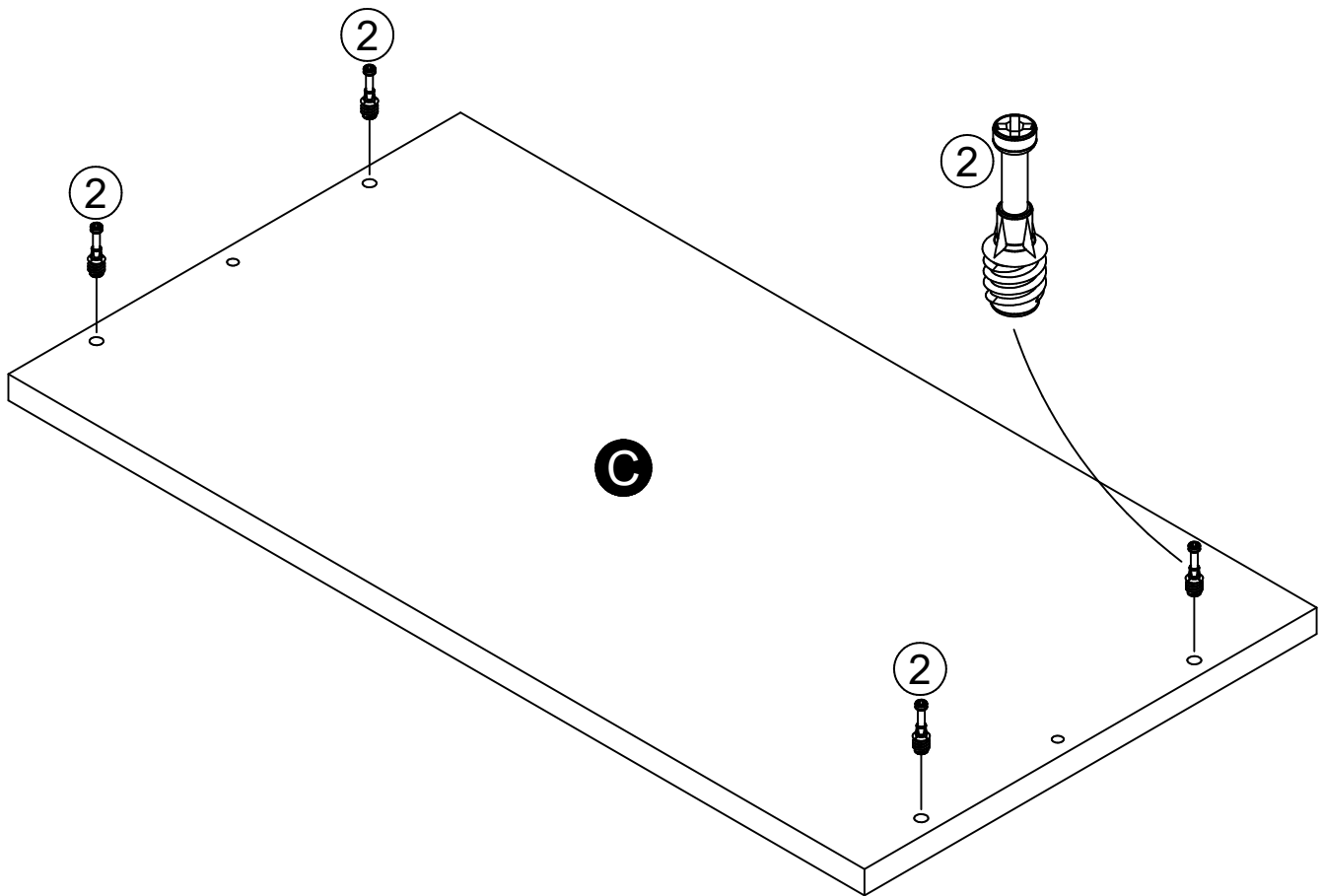
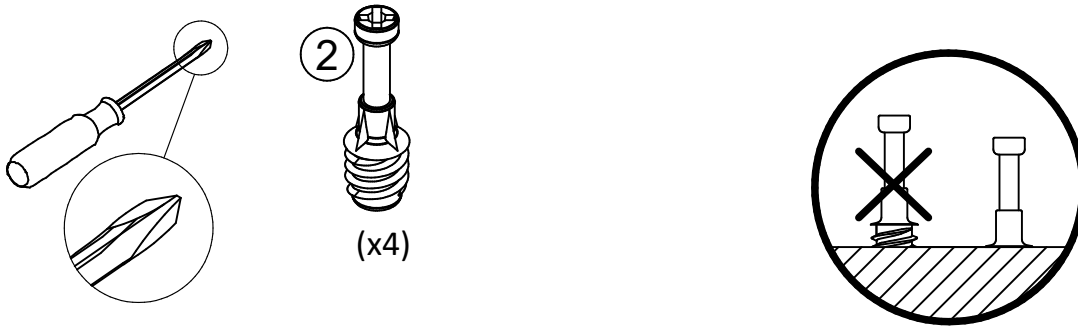

STEP 17

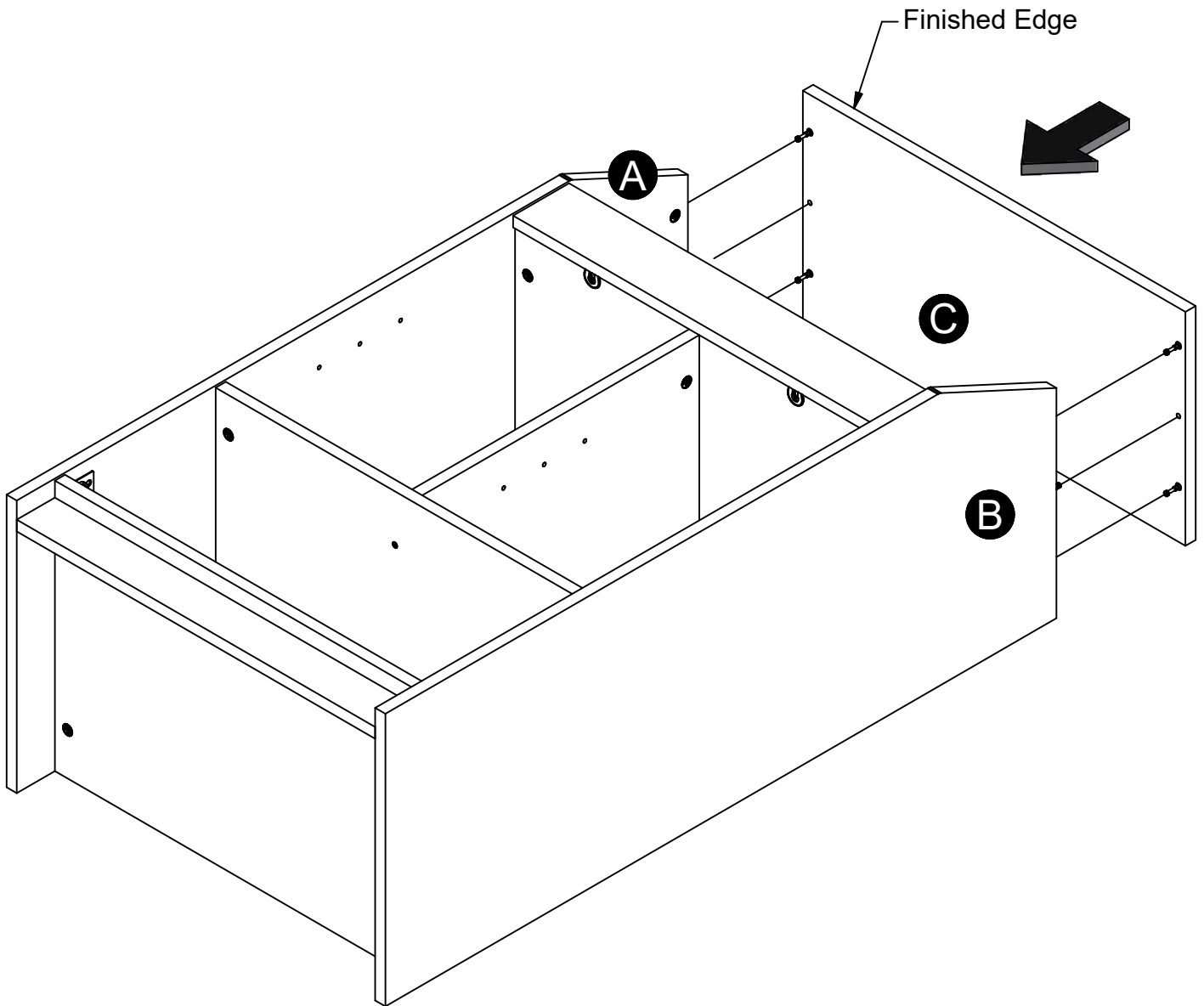
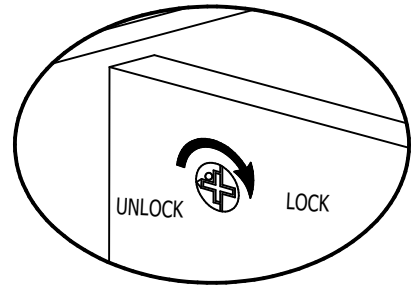
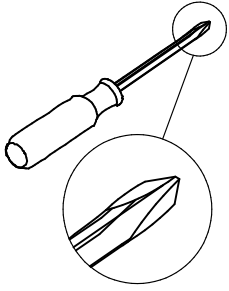

STEP 18

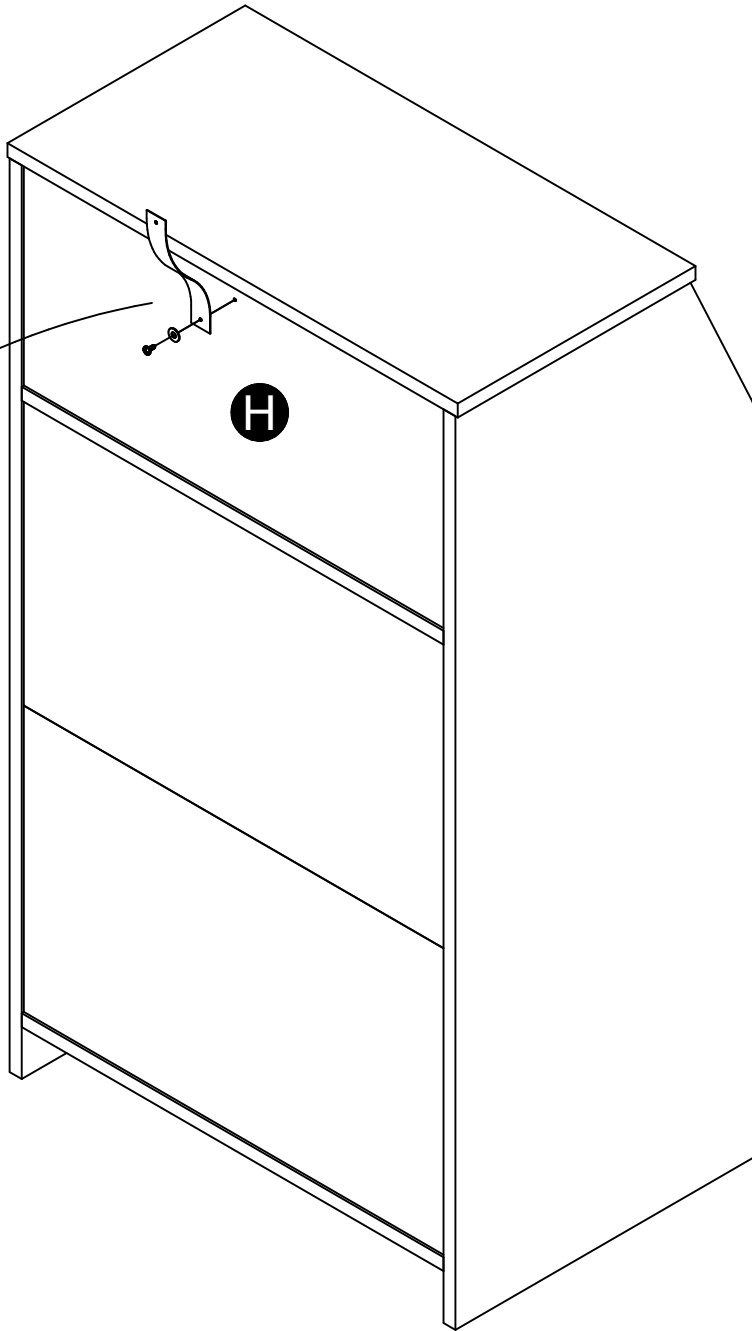
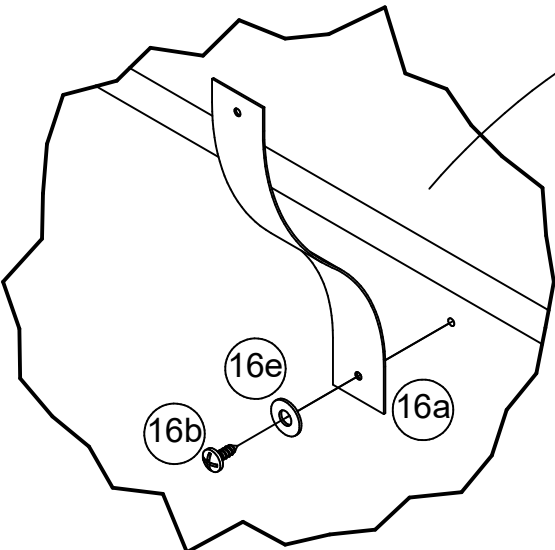
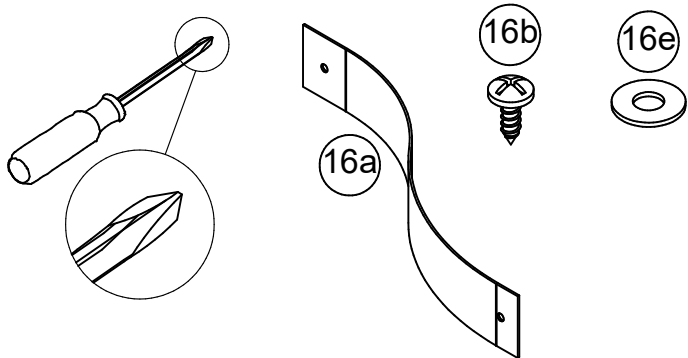

STEP 19

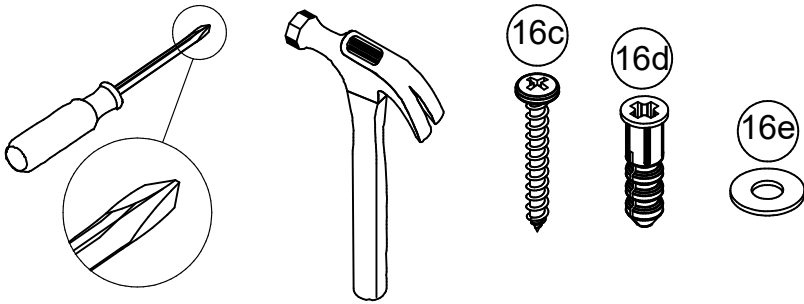

For Masonry, Concrete, or other wall materials:
Consult your local hardware store for appropriate anchors to securely attach the safety bracket.

IMPORTANT: THIS UNIT MUST BE SECURE TO THE WALL TO HELP PREVENT TIPOVER. FOLLOW THESE INSTRUCTIONS TO INSTALL THE ANTI-TIPPING SAFETY BRACKET PROVIDED WITH THIS PRODUCT.

WARNING

Serious or fatal crushing injuries can occur from furniture tipover.

To prevent tipover:

- * Install tipover restraint provided
- * Place heaviest items in the lowest drawers
- * Unless specifically designed to accommodate, do not set TVs or other heavy objects on the top of this product
- * Never allow children to climb or hang on drawers, door, or shelves
- * Never open more than one drawer at a time

Use of tipover restraints may only reduce, but not eliminate the risk of tipover

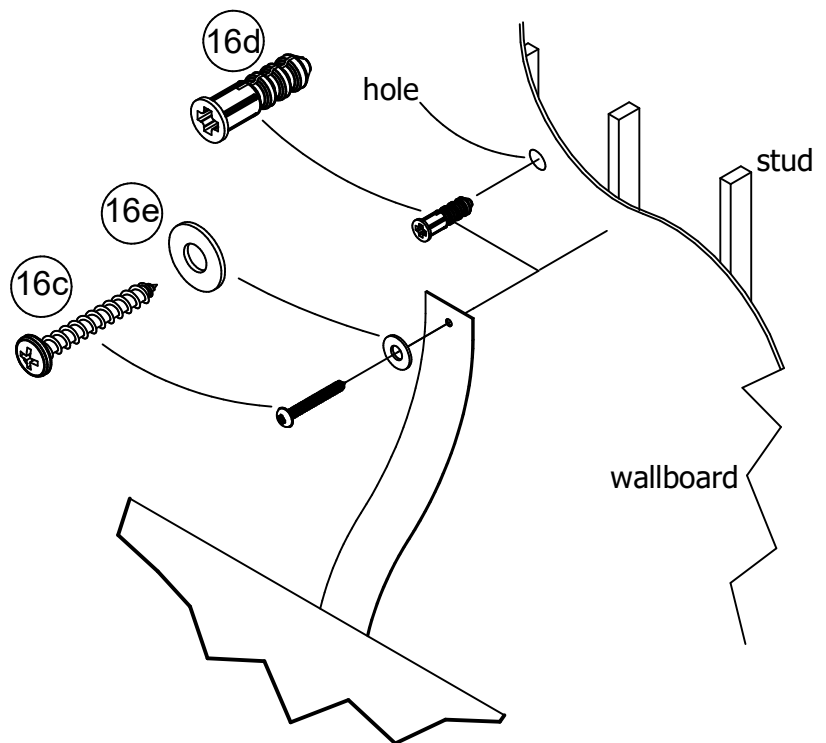

OPTION 1: Attachment into a wall stud (preferred method)

Using a stud finder, locate a stud in the wall. Place your unit against the wall, with the safety bracket aligned in this location. To make driving the screw easier, you can drill a 1/8" diameter pilot hole (3mm) through the safety bracket into the stud. Drive the screw through the safety bracket into the wall stud.

OPTION 2: Attachment into drywall

Locate your unit where desired against a wall and mark the wall through the safety bracket, then move your unit aside. Drill a 3/16" diameter hole (5mm) into the wallboard. Tap the wall anchor into the hole until it is flush. Move your unit into location and fasten the wall bracket to the wall anchor with the screw.

STEP 20

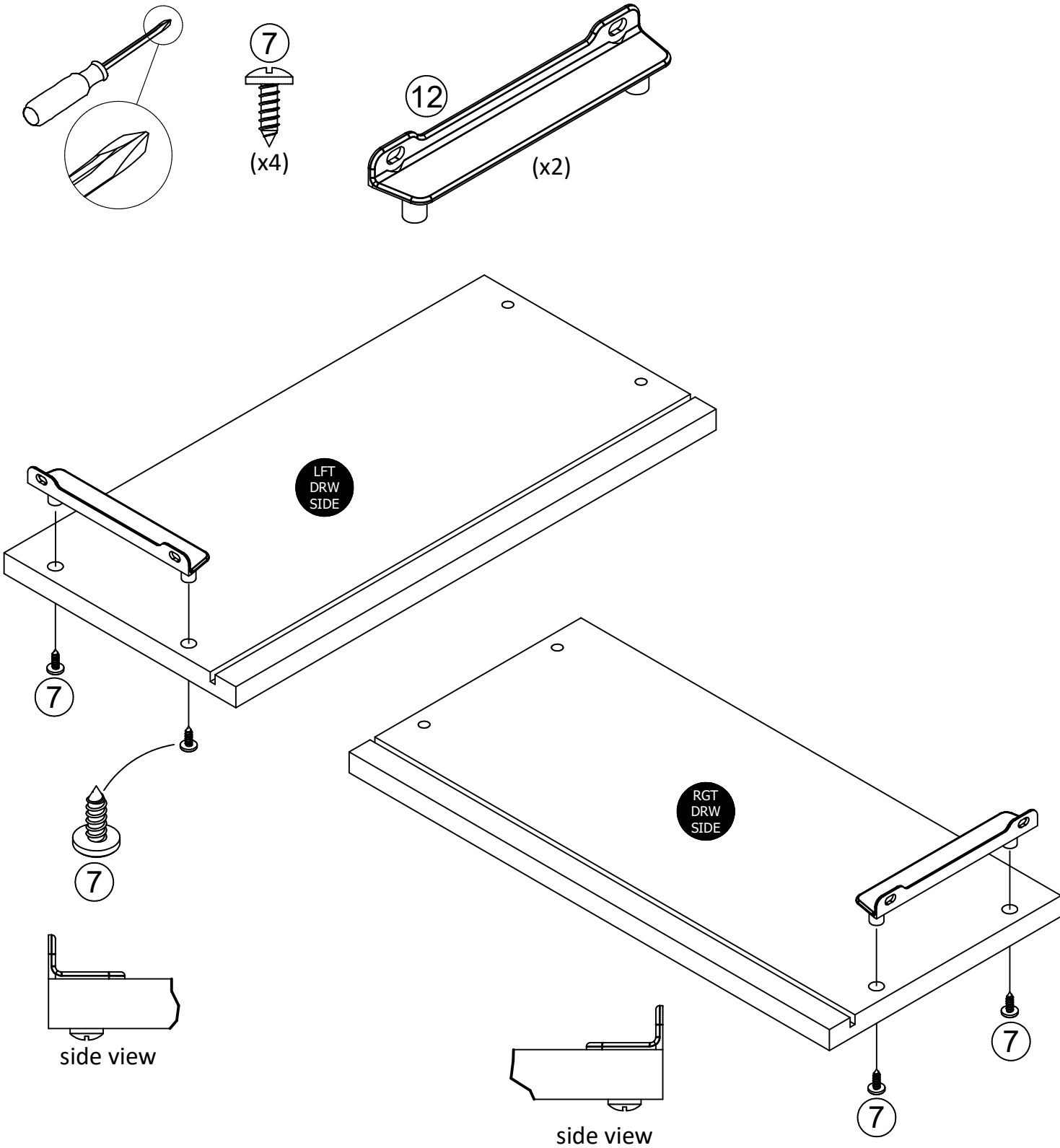

STEP 21

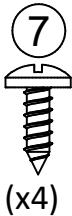
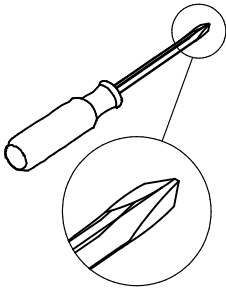

Be sure the groove in the drawer sides are centered with groove in drawer front.

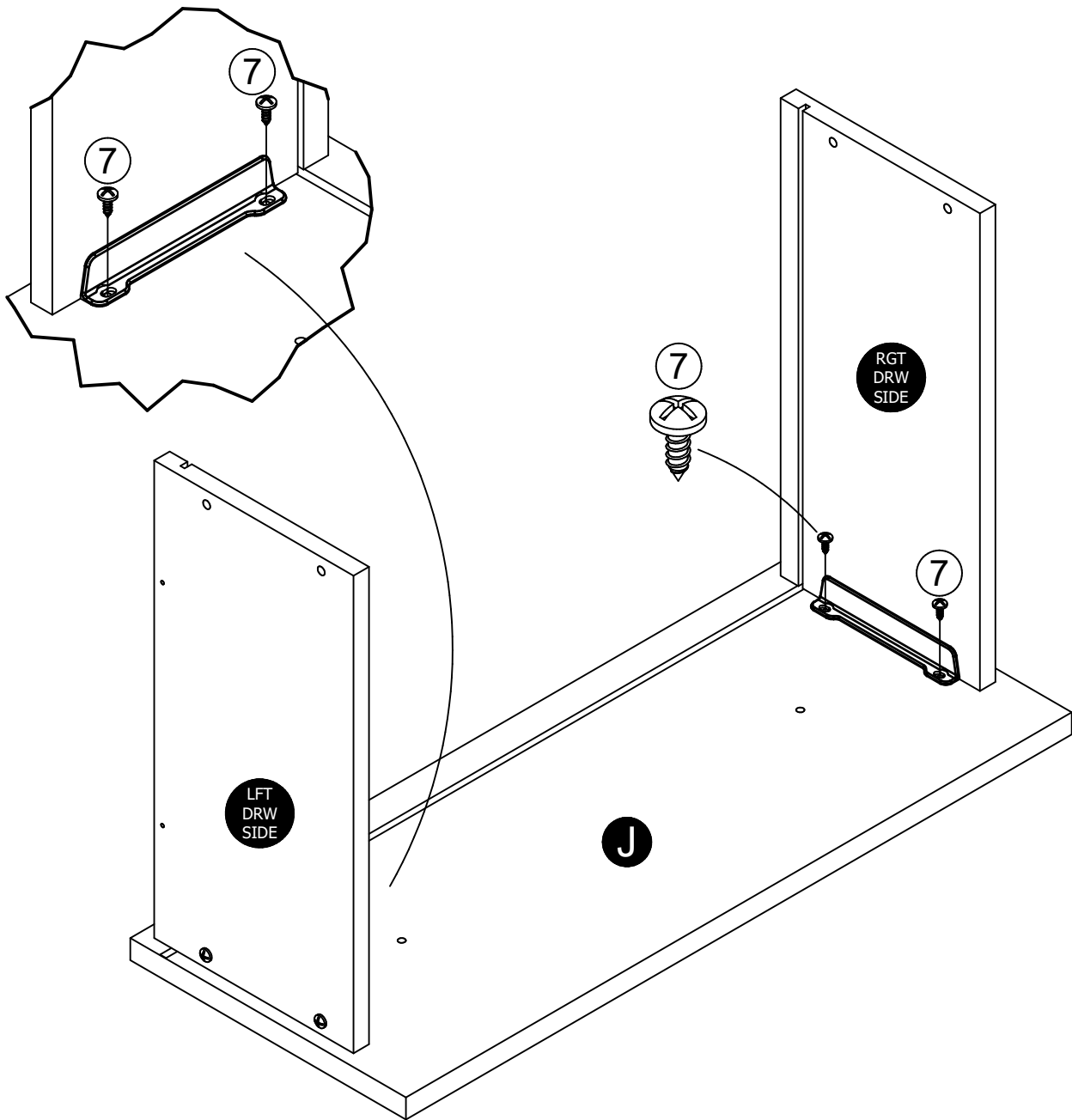

STEP 22

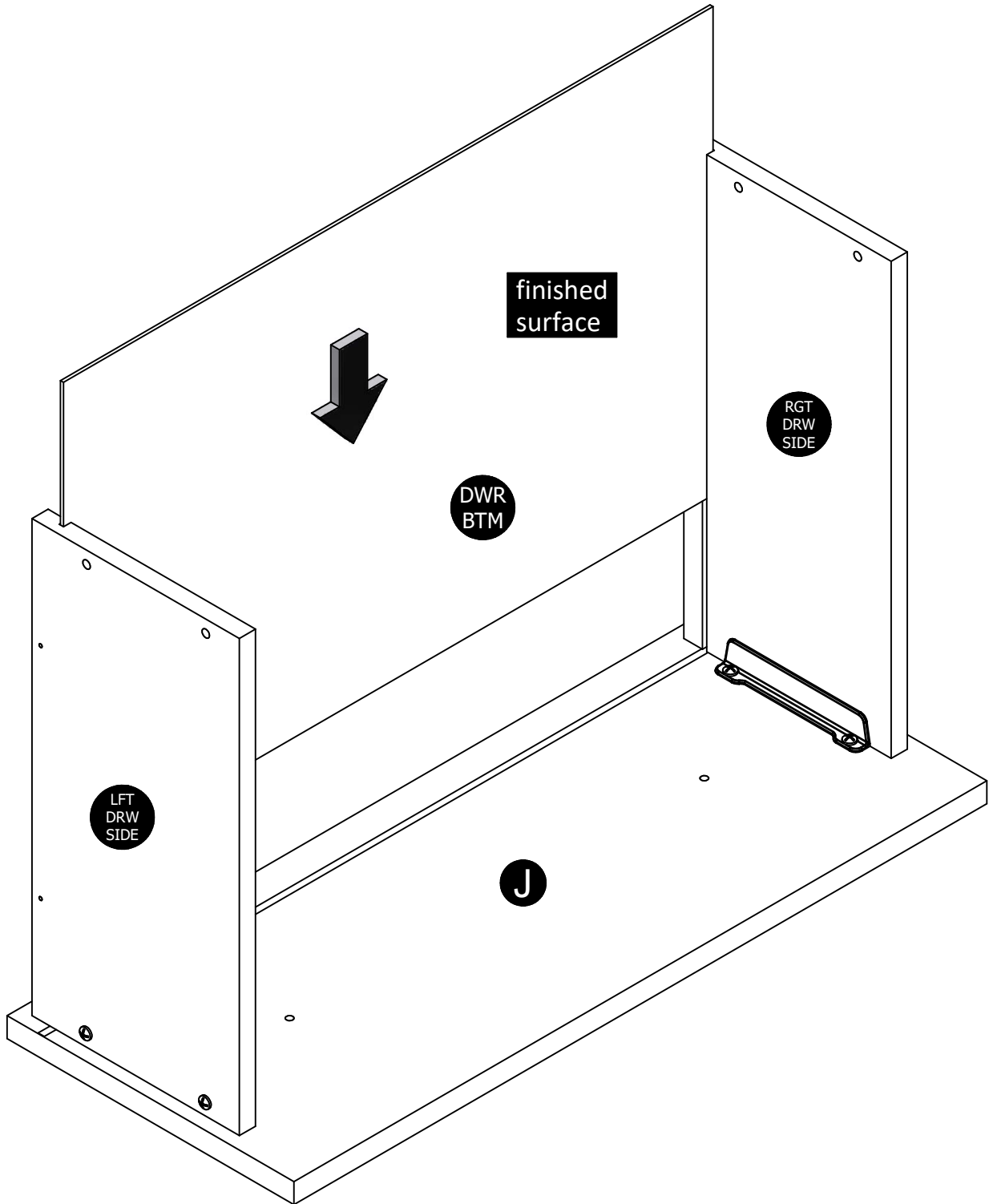

STEP 23

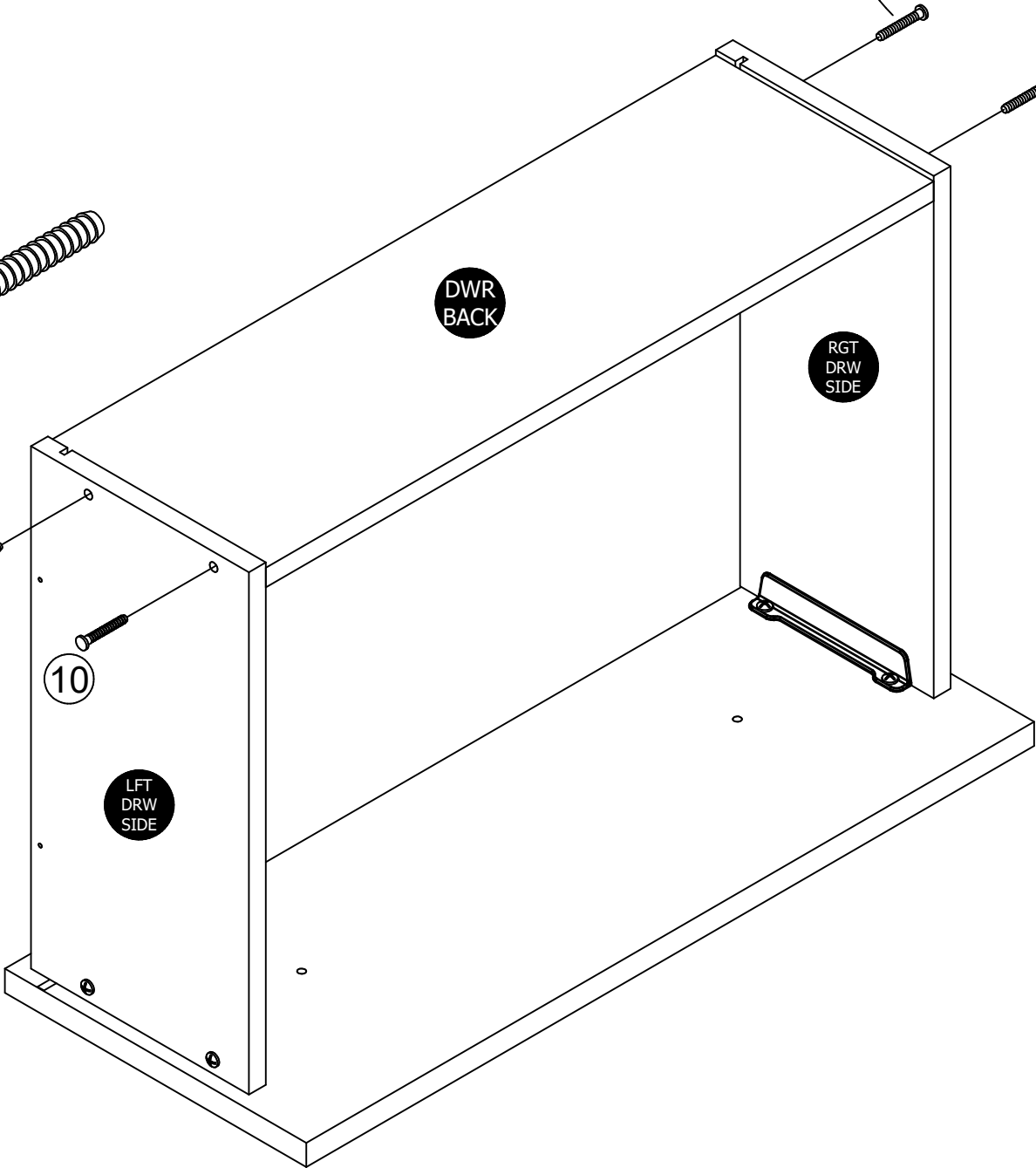
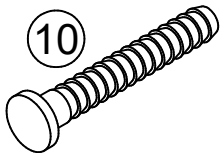
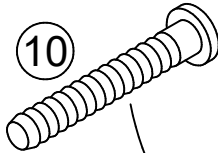
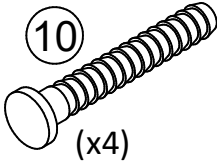

STEP 24

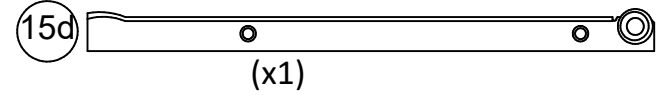
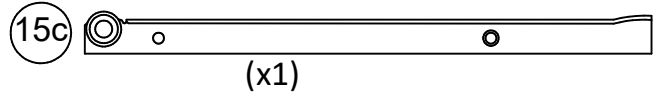
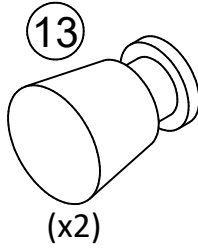
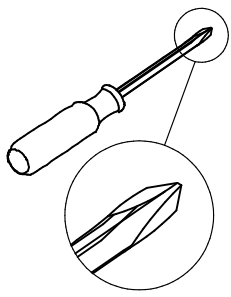

Attach the slides first and then the knobs.

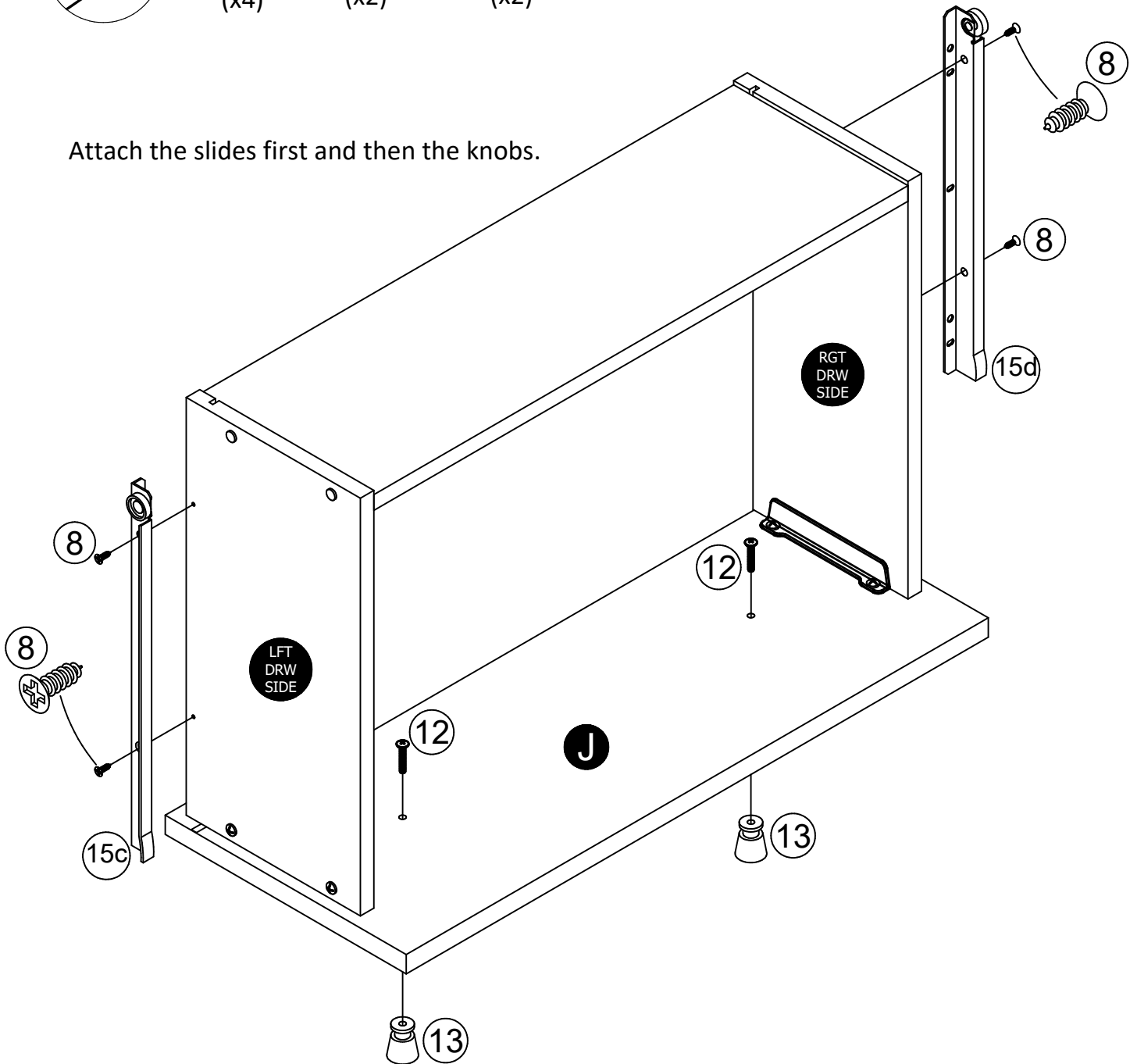

STEP 25

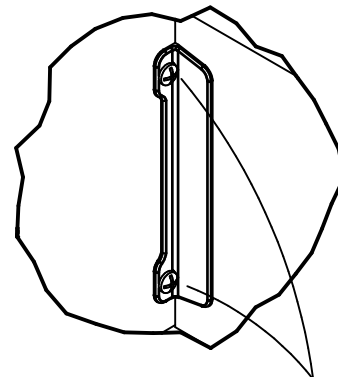
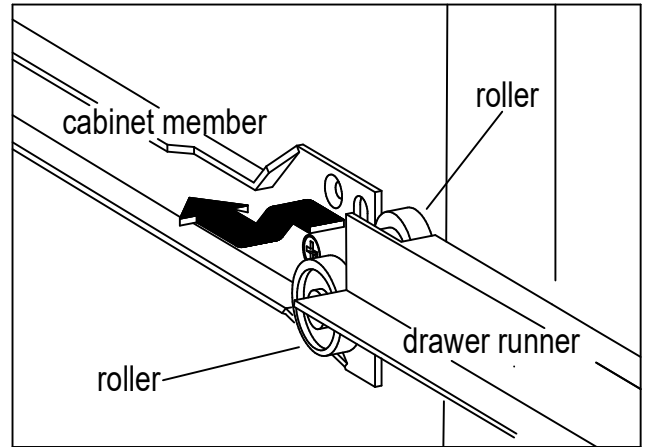
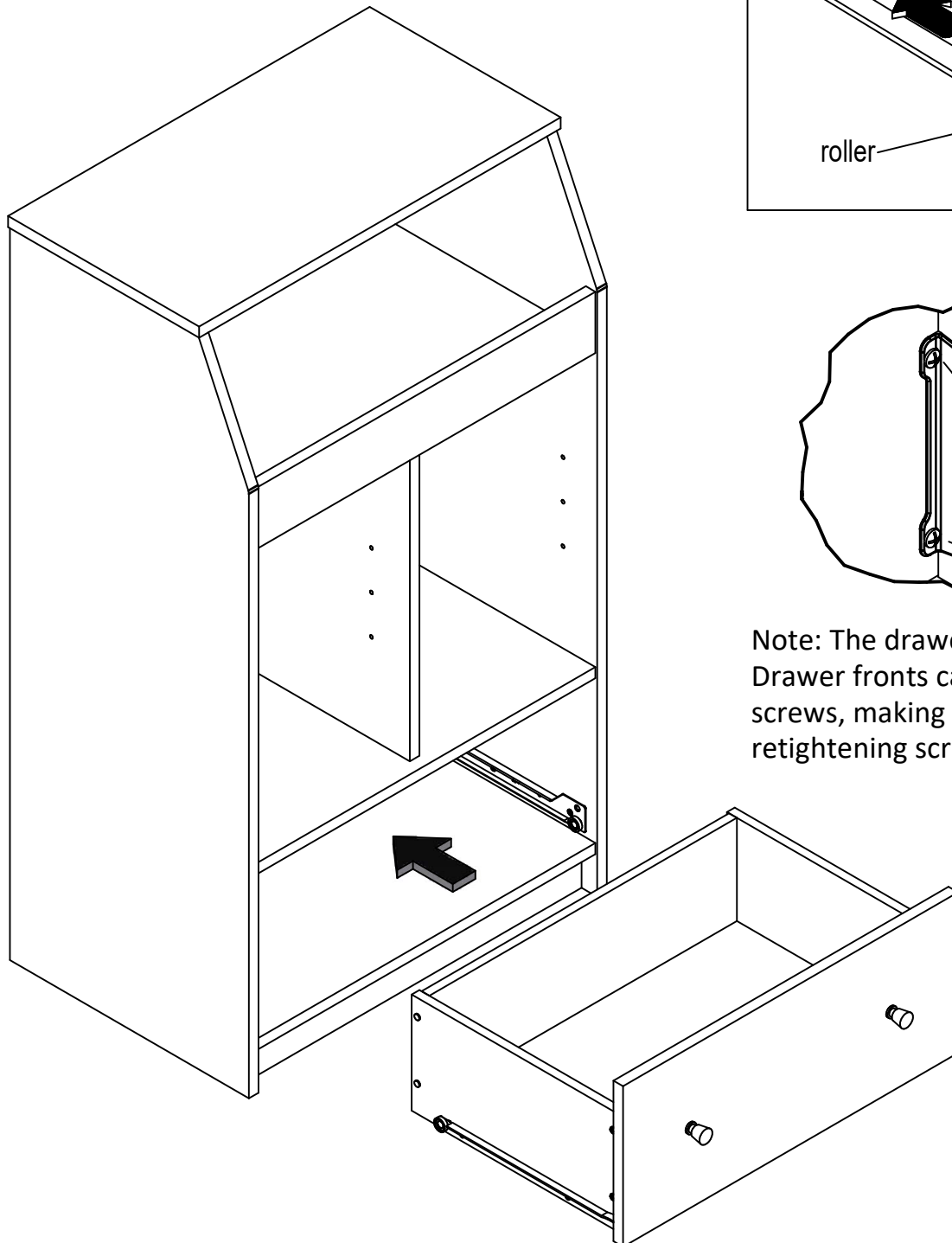

Note: The drawer bracket holes are slotted. Drawer fronts can be adjusted by loosening screws, making needed adjustments and retightening screws.

STEP 26

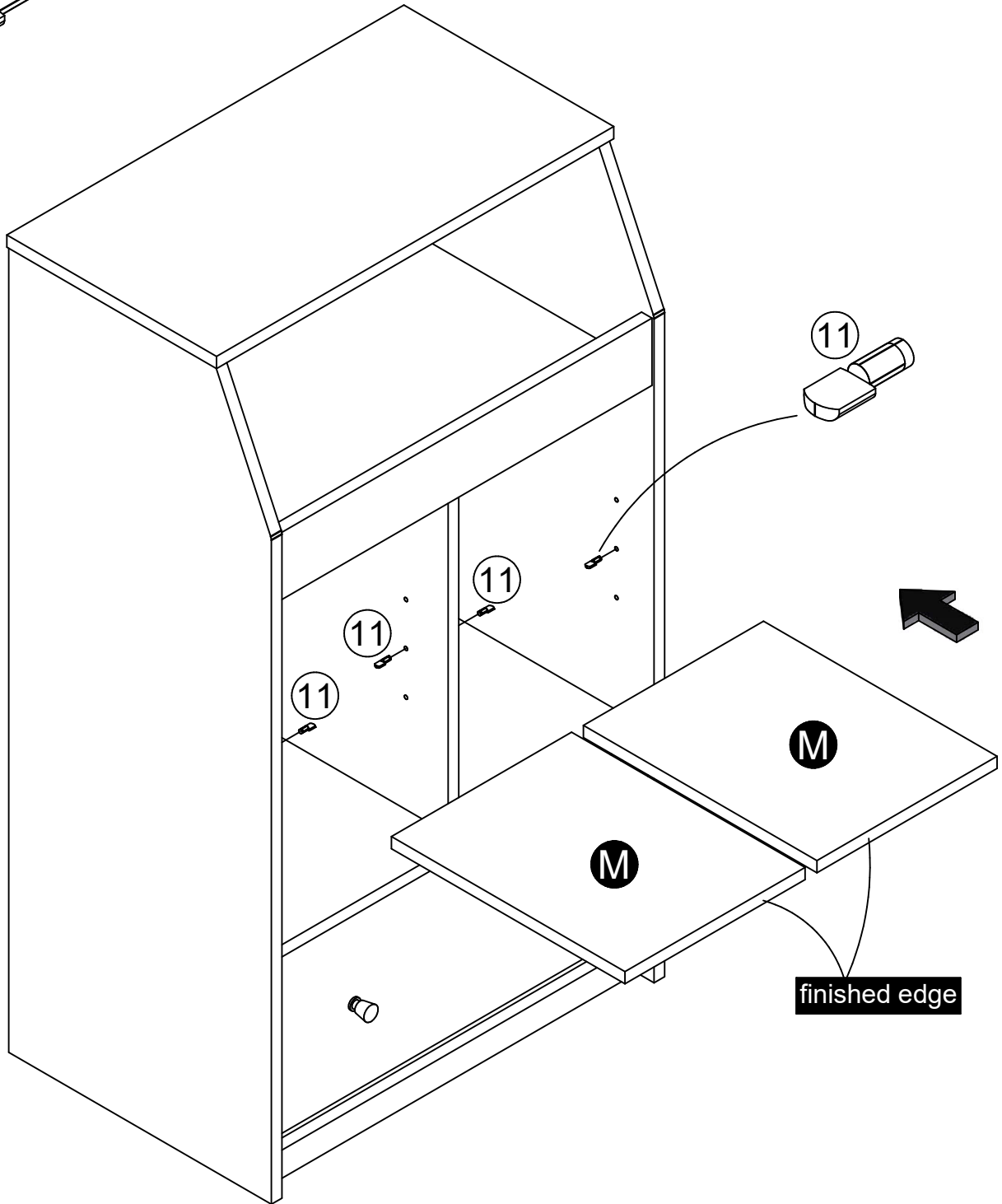
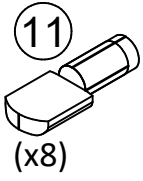

Maximum Loads

This unit has been designed to support the maximum loads shown. Exceeding these load limits could cause sagging, instability, product collapse, and/or serious injury.

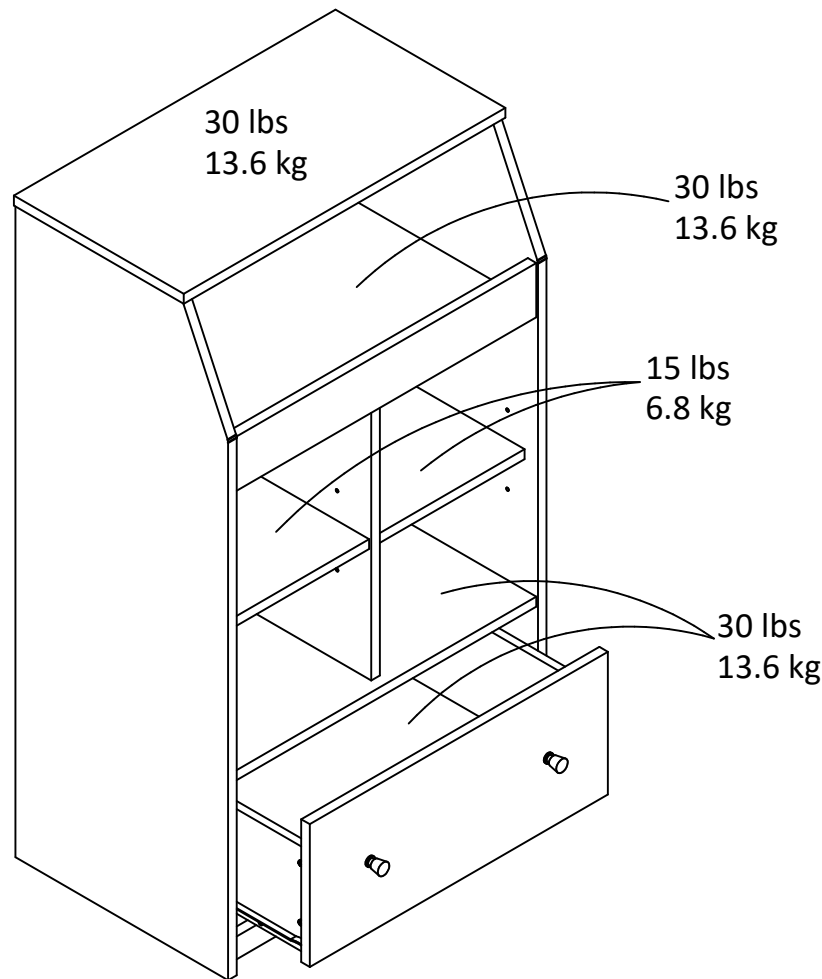

Warning: Risk of injury to persons - do not place a television on this furniture. This furniture is not approved for use with a television.

Certificate of Conformity

1. This certificate applies to the Dorel Home Furnishings, Inc. product identified by this instruction manual.
2. This certificate applies to compliance of this product with the CPSC Ban on Lead-Containing Paint (16 CFR 1303).
3. This product is distributed by: Dorel Home Furnishings, Inc.
410 East First Street South
Wright City, MO 63390
636-745-3351
4. Site of Manufacture: Tiffin OH
5. See front page of instruction manual for date of manufacture.

Register your product to receive the following:



- * New trend details - sneak peek on what's new
- * Surveys - have a voice within our community
- * Exclusive deals and discount codes
- * Quick and easy replacement part service

To register your product, visit ameriwoodhome.com

5 Star Rating



Visit your local retailer's website, rate your purchased product and leave us some feedback!

We would like to extend a big "Thank You" to all of our customers for taking the time to assemble this Ameriwood Home product, and to give us your valuable feedback.

*Thank
You!*

Cubierta Delantera

Este libro de instrucciones contiene información **IMPORTANTE** de seguridad. Por favor lea y manténgalo para referencia en el futuro.

No Regrese este producto! Comuníquese con nuestro amigoso equipo de servicio al cliente para obtener ayuda.

Llámenos al: 1-800-489-3351 (Gratis) Lunes - Viernes 9am - 5pm CST

Visitar: www.ameriwoodhome.com

PRECAUCION

Este mueble puede volcarse y causar graves heridas y/o muerte.

Anclar el mueble a un poste de madera en la pared (si esto se requiere).

No Permita que los niños monten el mueble.

Mantenga los artículos más pesados en los cajones de abajo.

Consejos Útiles (página 2)

- Abra su artículo en el área donde usted planea utilizarlo para evitar levantar y moverlo menos
- Identificar, ordenar y contar las piezas antes de intentar ensamblar
- Las clavijas de compresión se golpean con un martillo
- Las diapositivas están marcadas con una R (derecha) y L (izquierda) para la colocación correcta
- Asegúrese de que siempre este el punto localizado en la parte superior de bloqueador de leva este volteado hacia borde exterior
- Utilizar todos los clavos para el panel de atrás y distribuirlos por igual
- El panel de atrás debe utilizarse para asegurarse de que la unidad quede fija y firme
- No use químicas fuertes ni limpiadores abrasivos en este artículo
- Nunca empuje, tire ni arrastre los muebles

Antes de Que Empieces (página 3)

- Lea cuidadosamente cada paso y siga el orden correcto
- Separar y contar todas sus piezas y hardware
- Dése suficiente espacio para el proceso de ensamble
- Tenga las siguientes herramientas: destornillador de cabeza plana, #2 cabeza Phillips
Destornillador y martillo
- Precaución: Si usa un taladro electrónico o un destornillador eléctrico para atornillar, por favor asegúrese que deje de atornillar cuando el tornillo este apretado. Fallar hacer esto puede causar barrer el tornillo.

Sistema de fijar el bloqueo de leva (página 3)

Esta sistema de fijar el bloqueo de leva sera usado en todo el proceso ensamble.

Página 14

Asegúrese de que el conector (4) esté colocado como se muestra antes de insertarlo en el orificio. Golpee con un martillo para insertarlo completamente.

Página 15

Gire el tornillo en el sentido de las agujas del reloj para bloquearlo.

Página 17

Asegúrese de que el conector (4) esté colocado como se muestra antes de insertarlo en el orificio. Golpee con un martillo para insertarlo completamente.

Gire el tornillo en el sentido de las agujas del reloj para bloquearlo.

Página 23

Nota:

Agujero hacia arriba y en la parte trasera.

Página 28

Para mampostería, hormigón u otros materiales de pared:

Consulte en su ferretería local los anclajes apropiados para fijar el soporte de seguridad de forma segura.

IMPORTANTE: ESTA UNIDAD DEBE ESTAR FIJADA A LA PARED PARA EVITAR QUE SE VUELQUE. SIGA ESTAS INSTRUCCIONES PARA INSTALAR EL SOPORTE DE SEGURIDAD ANTIVUELCO SUMINISTRADO CON ESTE PRODUCTO.

ADVERTENCIA

El vuelco del mueble puede provocar lesiones graves o mortales por aplastamiento.

Para evitar el vuelco:

- * Instale el soporte antivuelco suministrado
- * Coloque los artículos más pesados en los cajones inferiores
- * A menos que esté diseñado específicamente para ello, no coloque televisores u otros objetos pesados en la parte superior de este producto
- * No permita nunca que los niños trepen o se cuelguen de los cajones, puertas o estantes
- * No abra nunca más de un cajón a la vez

El uso de dispositivos de sujeción para el vuelco solo puede reducir, pero no eliminar, el riesgo de vuelco

OPCIÓN 1: Fijación en un montante de la pared (método preferido)

Con un localizador de montantes, localice un montante en la pared. Coloque su unidad contra la pared, con el soporte de seguridad alineado en esta ubicación. Para facilitar la colocación del tornillo, puede perforar un agujero piloto de 1/8" de diámetro (3 mm) a través del soporte de seguridad en el montante. Introduzca el tornillo a través del soporte de seguridad en el montante de la pared.

OPCIÓN 2: Fijación en una pared de yeso laminado

Ubique su unidad en el lugar deseado contra una pared y marque la pared a través del soporte de seguridad, luego mueva su unidad a un lado. Perfore un agujero de 3/16" de diámetro (5 mm) en la pared. Golpee el anclaje de pared en el agujero hasta que esté al ras. Mueva su unidad a su ubicación y fije el soporte de pared al anclaje de pared con el tornillo.

Página 30

Asegúrese de que la ranura de los lados del cajón esté centrada con la ranura del frente del cajón.

Página 33

Coloque primero las guías y luego los pomos.

Página 34

Nota: Los agujeros de los soportes de los cajones están ranurados. Los frentes de los cajones se pueden ajustar aflojando los tornillos, haciendo los ajustes necesarios y volviendo a apretar los tornillos.

Página 36

CARGA MAXIMA

Esta unidad ha sido diseñada para soportar las cargas máximas mostradas. Sobrepasar dichos límites de carga podría ocasionar hundimientos, inestabilidad, colapso del producto y/o lesiones graves.

Advertencia: riesgo de lesiones personales - no coloque televisores sobre este mueble. Este mueble no está aprobado para ser usado con un televisor.

Página 37

Registre su producto para recibir lo siguiente:

- * Detalles de nuevas tendencias - Vistazo a lo nuevo
- * Encuestas - alec su voz entre su comunidad
- * Códigos de ofertas y descuentos exclusivos
- * Fácil y rápido servicio de partes de remplace

Para registrar su producto, visite ameriwoodhome.com

Clasificación de 5 estrellas

Visite el sitio web de su tienda local, califique su comprado y denos sus comentarios!

Nos gustaría enviar un gran "Agradecimiento" a todos nuestros clientes por tomarse el tiempo de ensamblar este producto de Ameriwood Home, y por darnos sus valiosos comentarios.

Gracias

Couverture Avant

CE LIVRET D'INSTRUCTION CONTIENT DES INFORMATIONS **IMPORTANTES** SUR LA SÉCURITÉ. VEUILLEZ LIRE ET GARDER POUR UNE RÉFÉRENCE FUTURE

Ne retournez pas ce produit! Contactez notre équipe de service à la clientèle amicale d'abord pour obtenir de l'aide.

Appelez-nous: 1-800-489-3351 (sans frais) du Lundi au Vendredi de 9h à 17h Heure Centrale

Visitez: www.ameriwoodhome.com

ATTENTION

Le meuble peut basculer et causer des blessures graves ou la mort.

Ancrer le meuble à une planche murale dans le mur (si indiqué).

Ne laissez pas les enfants grimper sur le meuble.

Placez les articles lourds sur les étagères ou dans les tiroirs inférieurs.

Astuces Utiles (page 2)

-Ouvrez votre article dans la zone que vous prévoyez de le garder pour moins de levage lourd

-Identifier, trier et compter les pièces avant d'essayer d'assembler

-Les goujons de compression sont taraudés avec un Marteau

-Les glissières sont marquées d'un R (droit) et d'un L (gauche) pour un bon placement

-Assurez-vous toujours de faire face la pointe situé sur le haut de la Serrure de Came vers le bord extérieur

-Utiliser tous les clous fournis pour le panneau arrière et les répartir également

-Le panneau arrière doit être utilisé pour vous assurer que votre appareil est robuste

-N'utilisez pas de produits chimiques agressifs ou de nettoyeurs abrasifs sur cet appareil

-Ne jamais pousser, tirer, ou faire glisser votre meuble

Avant de Commencer (page 3)

-Lisez attentivement chaque étape et suivez le bon ordre

-Séparez et comptez toutes vos pièces et matériaux

-Donnez-vous suffisamment de place pour l'assemblage

-Avoir les outils suivants: tournevis à tête plate, #2 tournevis Phillips, et Marteau

-Attention: Si vous utilisez une perceuse électrique ou un tournevis électrique pour visser, veillez à ralentir et arrêter lorsque la vis est bien serrée. Le non-respect de cette consigne peut endommager la vis.

Système de Fixation de Came (page 3)

Ce Système de Fixation de Came sera utilisé tout au long de l'assemblage

Page 14

Assurez-vous que le connecteur (4) est positionné comme indiqué avant de l'insérer dans le trou. Tapez avec un marteau pour l'insérer complètement.

Page 15

Tournez la vis dans le sens des aiguilles d'une montre pour la bloquer.

Page 17

Assurez-vous que le connecteur (4) est positionné comme indiqué avant de l'insérer dans le trou. Tapez avec un marteau pour l'insérer complètement.

Tournez la vis dans le sens des aiguilles d'une montre pour la bloquer.

Page 23

Remarque :

Trou vers le haut et sur le côté arrière.

Page 28

Pour la maçonnerie, le béton ou d'autres matériaux muraux :

Consultez votre quincaillerie locale pour obtenir des ancrages appropriés afin de fixer solidement le support de sécurité.

IMPORTANT : CE MATÉRIEL DOIT ÊTRE FIXÉ AU MUR POUR ÉVITER LE BASCULEMENT. SUIVEZ CES INSTRUCTIONS POUR INSTALLER LE SUPPORT DE SÉCURITÉ ANTI-BASCULEMENT FOURNI AVEC CE PRODUIT.

AVERTISSEMENT

Le basculement d'un meuble peut entraîner des blessures graves ou mortelles par écrasement.

Pour éviter le basculement :

- * Installer le dispositif anti-basculement prévu
- * Placez les articles les plus lourds dans les tiroirs les plus bas
- * Ne posez pas de téléviseur ou d'autres objets lourds sur l'appareil, à moins qu'il ne soit spécifiquement conçu pour cela
- * Ne permettez jamais aux enfants de grimper ou de s'accrocher aux tiroirs, aux portes ou aux étagères
- * N'ouvrez jamais plus d'un tiroir à la fois

L'utilisation de dispositifs anti-basculement peut seulement réduire, et non éliminer le risque de basculement.

OPTION 1 : Fixation dans un montant de mur (méthode préférée)

À l'aide d'un détecteur de montants, localisez un montant dans le mur. Placez votre appareil contre le mur, avec le support de sécurité aligné à cet endroit. Pour faciliter l'insertion de la vis, vous pouvez percer un trou pilote de 3 mm de diamètre à travers le support de sécurité dans le montant. Enfoncez la vis à travers le support de sécurité dans le montant du mur.

OPTION 2 : Fixation dans les cloisons sèches

Placez votre matériel à l'endroit souhaité contre un mur et marquez le mur à travers le support de sécurité, puis mettez votre matériel de côté. Percez un trou de 3/16" de diamètre (5 mm) dans le panneau mural. Tapez sur l'ancrage mural dans le trou jusqu'à ce qu'il soit affleurant. Mettez votre appareil en place et fixez le support mural à l'ancrage mural à l'aide de la vis.

Page 30

Assurez-vous que la rainure des côtés du tiroir est centrée sur la rainure de l'avant du tiroir.

Page 33

Fixez d'abord les glissières, puis les boutons.

Page 34

Remarque : les trous des supports de tiroir sont fendus. Les façades des tiroirs peuvent être ajustées en desserrant les vis, en effectuant les ajustements nécessaires et en resserrant les vis.

Page 36

CHARGES MAXIMALES

Ce meuble a été conçu pour supporter les charges maximales indiquées. Le dépassement de ces dernières pourrait entraîner un affaissement, une instabilité, un effondrement du produit et/ou des blessures graves.

Avvertissement : risque de blessure pour les personnes - ne placez pas de téléviseur sur ce meuble. Il n'est pas approuvé pour un usage avec un téléviseur.

Page 37

Enregistrez votre produit pour recevoir les éléments suivantes:

- * Détails sur les nouvelles tendances - un aperçu sur les nouveautés
- * Sondages - avoir une voix au sein de notre communauté
- * Offres exclusives et codes promo
- * Service de pièces de rechange rapide et facile

Pour enregistrer votre produit, visitez ameriwoodhome.com

5 Étoiles

Visitez le site Web de votre détaillant local, évaluez votre produit acheté et laissez-nous quelques commentaires !

Nous tenons à offrir un grand "Merci" à tous nos clients pour avoir pris le temps d'assembler ce produit "Ameriwood Home", et de nous donner vos commentaires précieux.

Merci